

國 臺灣大學資訊管 研究所碩士 文

指導教授： 永松 博士

顏宏旭 博士

質性光波長多工光網 之
交換器配置演算法

Switch Placement Algorithms in Optical
WDM Heterogeneous Networks

研究生： 張孝澤 撰

中華民國 九十四 七月



質性光波長多工光網 之 交換器配置演算法

Switch Placement Algorithms in Optical WDM Heterogeneous Networks



本文係提交國 台灣大學
資訊管 學系研究所作為完成碩士
學位所需條件之一部分

研究生： 張孝澤 撰

中 華 民 國 九 十 四 七 月



謝 誌

本文的完成，象徵人生求學生涯的一個階段，謹以此篇文章獻給我的父母張克明先生與王寶煥女士，感謝您們在我求學生涯中全心的支持、鼓勵與包容，讓我毫無後顧之憂，得以如此順遂地完成學業。

感謝恩師 永松博士，大學四年的導師，研究所的指導，但讓我學習、了解到您對學術研究的執著與熱情，您也時常與我們分享人生經驗以及做人做事的道理。期許自己能如師所勉勵，以積極認真的態度、包容的心、多聽他人的聲音，面對人生往後的旅程與挑戰。同時要感謝顏宏旭博士細心的指導，您總是很有耐心的與我們討論，厭其煩的解釋給我們聽，讓我獲益匪淺，沒有您絕對不會有這麼完整的論文內容。

本文的完成，承蒙趙啟超博士、俊賢博士與盈達博士於口試時給予多寶貴的指正與建議，使得本文的內容臻完備。感謝孫雅博士於大學專題期間對於我在網路領域研究上的啟蒙與指導。感謝詩偉博士的多次指導，讓我對於光網有深層的認識。

在網路最佳化實驗室的成員，特別感謝明源一的陪伴與扶持，書平、建宏、琳智，能與你們共同攜手完成碩士學業真好。感謝旭成學長與柏皓學長的指導與照顧，感謝學弟妹中、弘翕、文政、義與勇誠在我們忙於論文時多的協助。

在台大浮群期間認識一大群好朋友，謝謝所有小骨頭讓我這一下許多難忘美好的回憶，像極一首交響曲，由各個高低潮的篇章交織而成。23屆同屆伙伴間彼此的加油打氣是我努力向前堅持到最後的動力。另外，最要感謝好友欣穎與慧君不斷的支持與鼓勵，使我忘卻論文撰寫期間的苦悶與不安。

這幾年間我從大自然中學習、領悟到太多道理，走遍臺灣群山五十座百岳，讓我體會人之於自然何其渺小，期許自己在未來的人生中能對大自然有任何可能形式的貢獻，盡心呵護爾摩沙之美，讓更多人能有相同的感動。

張孝澤 謹

于台大資訊管理研究所

九十四 七月



文摘要

文題目： 質性光波長多工光網 之交換器配置演算法

作者：張孝澤

九十四 七月

指導教授： 永松 博士 顏宏旭 博士

隨著光波長多工光網 的 斷發展，一條光纖所能攜帶的光波長 目 斷以倍 增加，光網 交換器 (OXC) 的複雜 與成本也隨之增加。GMPLS 定義三種光交換的方式：光纖交換、光波段交換與光波長交換。而在 質性網 下，允許每個節點有其中一種光交換的能 。光網 建置成本最大的 源即是光網 交換器，而光網 交換器的成本又與其所使用的埠 目直接相關，因此當一條光纖能攜帶 百條光波長時，光波長交換器的成本也將提高 百倍，且交換器埠的 目至今仍有設計上的 瓶頸存在。

此篇 文的目的是希望在 質性網 下，妥當的規劃各節點，以最低的成本而能滿足網 上所需的靜態 要求。我們將這個問題建 成一個 學模型，透過目標函式與限制式 適當的描述此問題，是一個整 規劃的問題，問題本身具有高 的複雜性和困難 。因為光網 由與光波長配置的問題 (RWA) 已知為一個NP-hard的問題，而此問題隱含 RWA問題，因此此問題也是一個NP-hard問題，無法在有限的時間內以已知有效的演算法解決。因此我們採用最佳化 域中的 格 日鬆弛法 (Lagrangean Relaxation) 解決此問題。

另外，我們根據[8]中的RWA問題發展出一個簡 的交換器配置演算法，我們設計 項實驗在 同的網 撲下測試所提出演算法與簡 演算法相比，實驗結果顯示 有較佳的結果。

關鍵詞：光波長多工、光網路規劃、光纖交換、光波段交換、光波長交換、最佳化、拉格蘭日鬆弛法、數學規劃。



THESIS ABSTRACT

GRADUATE INSTITUTE OF INFORMATION MANAGEMENT

NATIONAL TAIWAN UNIVERSITY

NAME : HSIAO-TSE CHANG MONTH/YEAR : JUL, 2005

ADVISOR : YEONG-SUNG LIN

HONG-HSU YEN

SWITCH PLACEMENT ALGORITHMS IN OPTICAL WDM HETEROGENEOUS NETWORKS

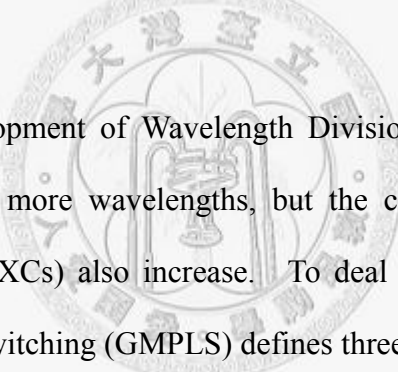

With the rapid development of Wavelength Division Multiplexing (WDM), a fiber can carry more and more wavelengths, but the complexity and the cost of Optical Cross-connects (OXC) also increase. To deal with the problem, General Multi-Protocol Labeling Switching (GMPLS) defines three kind of switching methods: fiber switch capable, waveband switch capable, and lambda switch capable. In a heterogeneous optical network, we allow each node to have one of the switching capabilities. OXC contribute most to the planning cost of optical networks, and the cost of OXC is in proportion to the number of ports. Therefore, while a fiber can carry hundreds of wavelengths, the cost of OXC increases proportionally. Furthermore, there is still a shortage of ports in the OXC design.

In this thesis, we allocate the switch nodes properly based on the lowest cost, and satisfy all the static traffic demand in a heterogeneous network. We model this problem as an integer programming problem with an objective function and several

constraints, which is very complicated. Since the routing and wavelength assignment problem (RWA) is a well known NP-hard problem, and our problem contains the RWA problem, our problem is also NP-hard. As we cannot solve it in polynomial time by well known algorithms, we adopt Lagrangean relaxation as the solution approach.

In addition, we propose a simple heuristic algorithm modified from an RWA problem, and conduct several experiments on different network topologies. We find that the experiment results of Lagrangean Relaxation are better than those of the simple heuristic algorithm.

Keywords: Fiber Switch, Lagrangean Relaxation Method, Lambda Switch, Mathematical Programming, Network Planning, Optimization, Waveband Switch, WDM.



Contents

謝 誌	I
文摘要	III
THESIS ABSTRACT	V
Contents	VII
List of Tables.....	IX
List of Figures.....	X
Chapter 1 Introduction.....	1
1.1 Background.....	1
1.1.1 DWDM Technology.....	1
1.1.2 OADM and OXC	4
1.1.3 GMPLS	8
1.2 Motivation.....	9
1.3 Literature Survey	11
1.3.1 RWA Related Issues	11
1.3.2 Homogeneous Network	12
1.3.3 Heterogeneous Network.....	15
1.3.4 Lagrangean Relaxation	15
1.4 Thesis Organization	17
Chapter 2 Problem Formulation	19
2.1 Problem Description	19
2.2 Graph Transformation.....	21
2.3 Notation.....	23
2.4 Problem Formulation	25
Chapter 3 Solution Approach	28
3.1 Lagrangean Relaxation	28
3.2 Subproblem.....	28
3.2.1 Subproblem 1	29
3.2.2 Subproblem 2	34
3.3 The Dual Problem and the Subgradient Method.....	36
3.4 Lagrangean Relaxation with Heuristics.....	37
Chapter 4 Getting Primal Feasible Solutions	39
4.1 Getting Primal Algorithms.....	39
4.2 Simple Heuristic Algorithms.....	42

Chapter 5	Computational Experiments	45
5.1	Experiment Environment	45
5.2	Seven-node Small Network	46
5.2.1	Network Topology	46
5.2.2	Solution Quality	47
5.2.3	Computation Time	50
5.3	GTE Network.....	52
5.3.1	Network Topology	52
5.3.2	Solution Quality	53
5.4	USA Network.....	55
5.4.1	Network Topology	55
5.4.2	Solution Quality	56
5.4.3	Computation Time	58
5.5	Discussion	59
5.5.1	Number of Wavelengths	59
5.5.2	Number of Wavebands	60
5.5.3	Scalability	61
Chapter 6	Conclusion and Future Work	63
6.1	Conclusion	63
6.2	Future Work	65
Reference	67

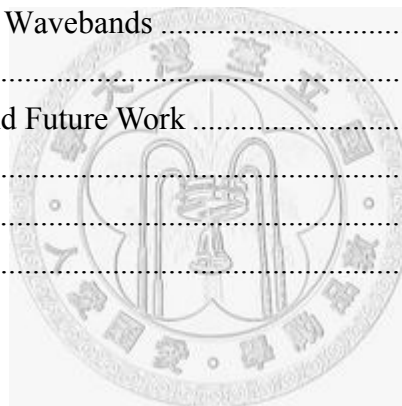

List of Tables

Table 2-1 The assumptions, objective, and constraints.....	20
Table 2-2 Input Parameters	23
Table 2-3 Decision Variables	24
Table 3-1 Find the minimum cost of K lightpaths for each OD-pair.....	31
Table 3-2 The proof of Min_K_Lightpath Algorithm.....	32
Table 3-3 Lemma 3.1	33
Table 3-4 Lagrangean Relaxation with Heuristics Algorithm	37
Table 4-1 Getting Primal Heuristic Algorithm.....	40
Table 4-2 Simple Heuristic Algorithm.....	43
Table 5-1 Parameters of the computational experiments.....	45
Table 5-2 Seven-node Small Network	46
Table 5-3 The improvement ratio in 7-node network	49
Table 5-4 GTE Network.....	52
Table 5-5 The improvement ratios of the GTE network.....	54
Table 5-6 The USA Network	55
Table 5-7 The improvement ratios of the USA network.....	57

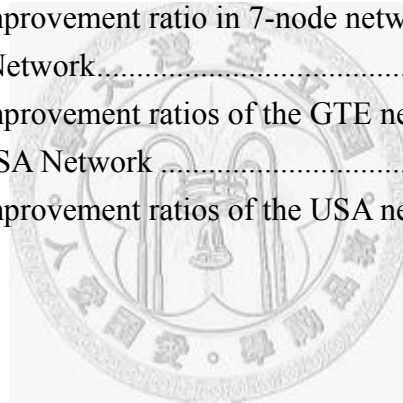

List of Figures

Figure 1-1 Wavelength Division Multiplexing Architecture	2
Figure 1-2 Fiber windows and their loss rates [13]	2
Figure 1-3 Ultimate fiber capacity [13]	3
Figure 1-4 Evolution of the fiber link capacity [14]	4
Figure 1-5 A Reconfigurable Optical Add-Drop Multiplexer [13]	5
Figure 1-6 A Optical Cross-Connect [13]	5
Figure 1-7 2-D MEMS Space switch	6
Figure 1-8 3-D MEMS Switch	7
Figure 1-9 GMPLS Control Plane	8
Figure 1-10 Fiber switch	10
Figure 1-11 Waveband switch	10
Figure 1-12 Wavelength (λ) switch	10
Figure 1-13 Three dimensions of the RWA related issues. [3]	12
Figure 1-14 Multigranularity Optical Cross-Connect [4]	13
Figure 1-15 Lagrangean Relaxation	17
Figure 2-1 Graph Transformation	22
Figure 4-1 Wasted Lambda Calculation	42
Figure 5-1 Seven-node Small Network Topology	46
Figure 5-2 The upper and lower bounds of the seven-node network	48
Figure 5-3 Gap of different traffic demand	48
Figure 5-4 The SA and LR solution quality in the 7-node small network ...	49
Figure 5-5 The number of iterations in the 7-node network	50
Figure 5-6 Computation time of the 7-node network	51
Figure 5-7 The GTE Network Topology	52
Figure 5-8 The upper and lower bounds in the GTE Network	53
Figure 5-9 The solution quality of SA and LR in the GTE network	54
Figure 5-10 The USA Network topology	55
Figure 5-11 The upper bound and lower bounds of the USA network	56
Figure 5-12 SA and LR solution quality in the USA network	57
Figure 5-13 The number of iterations in the USA Network	58
Figure 5-14 The computation time of the USA network	59
Figure 5-15 The cost structure of different numbers of wavelengths in a fiber	60
Figure 5-16 Cost structure of different number of waveband in a fiber	61

Chapter 1 Introduction

1.1 Background

1.1.1 DWDM Technology

WDM (Wavelength Division Multiplexing) technology or DWDM (Dense Wavelength Division Multiplexing) technology increases the carrying capacity of fibers. It can assign incoming optical signals to specific frequencies of light within a certain frequency band, called lambdas or channels. We can multiplex these lambdas all together and send them through the fiber simultaneously. Then, at the receiving end, we can separate the lambdas by using a demultiplexer. Figure 1-1 shows the architecture of WDM, in which the fiber carries n lambdas.

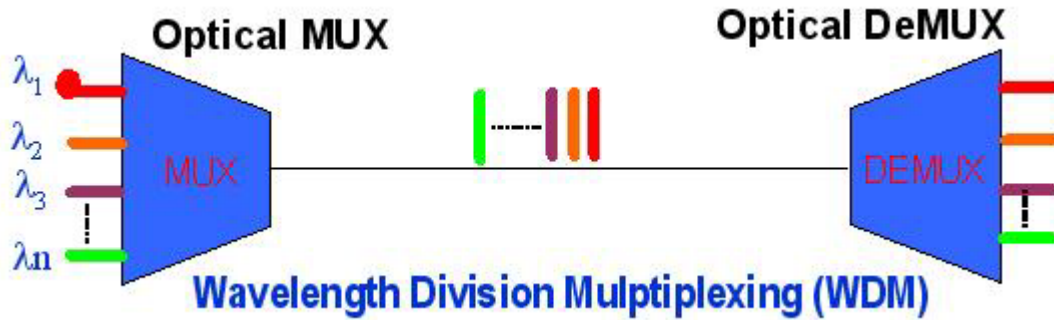

Figure 1-1 Wavelength Division Multiplexing Architecture

DWDM spaces the wavelengths closer than WDM. In the Figure 1-2, the 1st window is the most cost-efficient band, but due to the high loss rate, we can only utilize this band for short distance transmissions. We find that the 3rd, 4th, and 5th windows, called “C band”, “L band”, and “S band”, respectively, have relatively low loss rates. For example, the loss rate of C band is even lower than 0.2dB/KM, which means that the optical signal with C band wavelength will only decline by half after sixty kilometers of transmission. Therefore, we can use these three bands for DWDM.

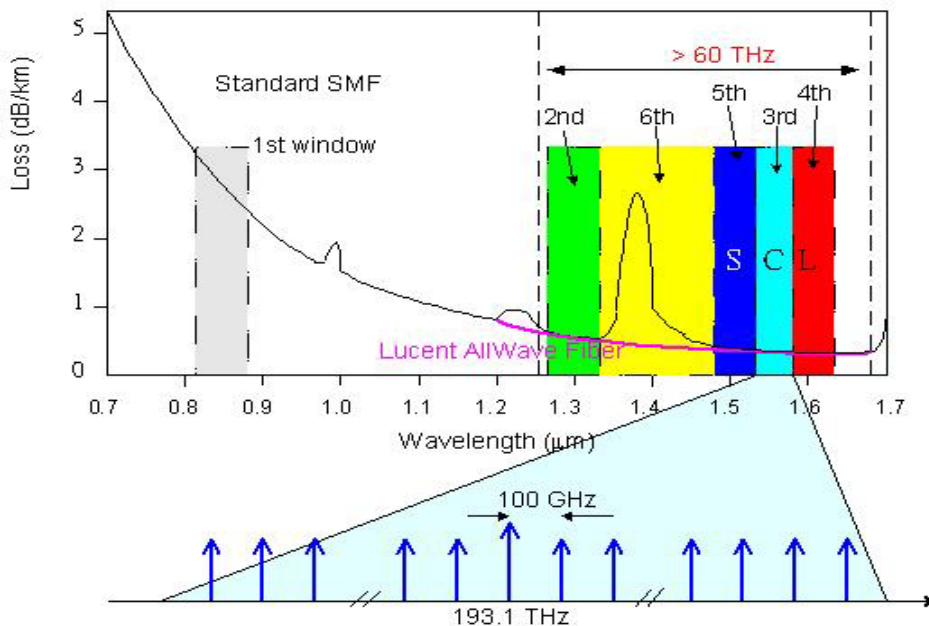

Figure 1-2 Fiber windows and their loss rates [13]

Nowadays, DWDM technology divides a fiber into more than 200 lambdas, and each lambda can carry more than 10 Gbps. In Figure 1-3, each fiber cable carries more than 100 fibers, each of which carries more than 200 lambdas, and each lambda carries more than 10 Gbps of traffic. Commercial products can easily achieve 2 Tbps per fiber.

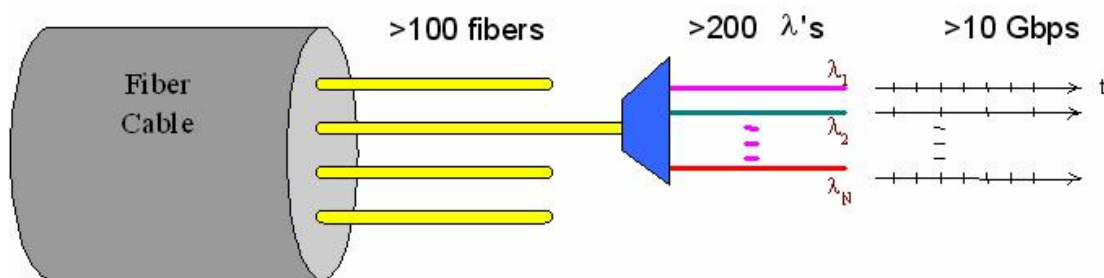

Figure 1-3 Ultimate fiber capacity [13]

In 2002, NEC demonstrated a single fiber with 273 lambdas, each with 40 Gbps data rate, transmitting across 117 kilometers, so the total capacity of the fiber was 10.92 Tbps. Figure 1-4 shows the evolution of the fiber capacity in WDM and TDM from 1993 to 2003. Note that in TDM, there is no wavelength division multiplexing. Hence, there is only one lambda on each fiber link. In WDM, we can see that the lambdas divided by a single fiber increase from 8 to 273.

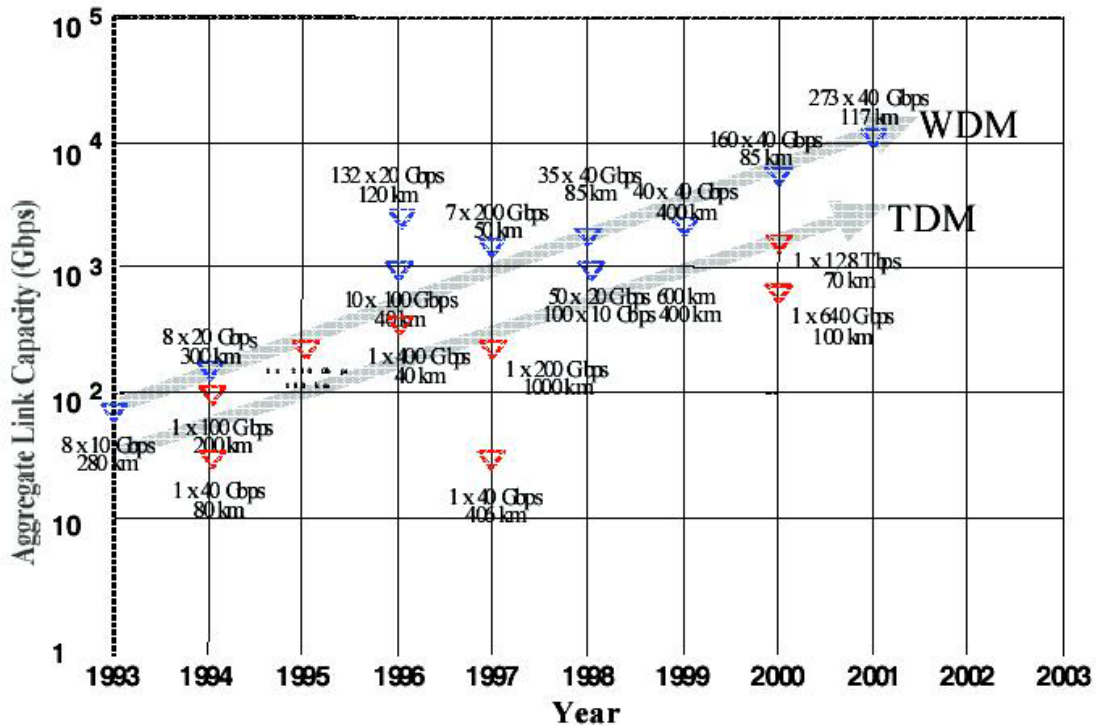

Figure 1-4 Evolution of the fiber link capacity [14]

1.1.2 OADM and OXC

An OADM (optical add-drop multiplexer) can drop lambdas from-or add lambdas to-a fiber. Fixed OADMs can only drop and add specific lambdas, while reconfigurable OADMs (see figure 1-5) can dynamically set the lambda to be dropped or added. An optical add-drop multiplexer can be only connected to one fiber and each lambda needs a 2x2 switch. When the 2X2 switch setting is parallel, the incoming lambda bypasses this OADM. When the switch setting is crossable, the switch drops the incoming lambda, adding a new lambda to the fiber.

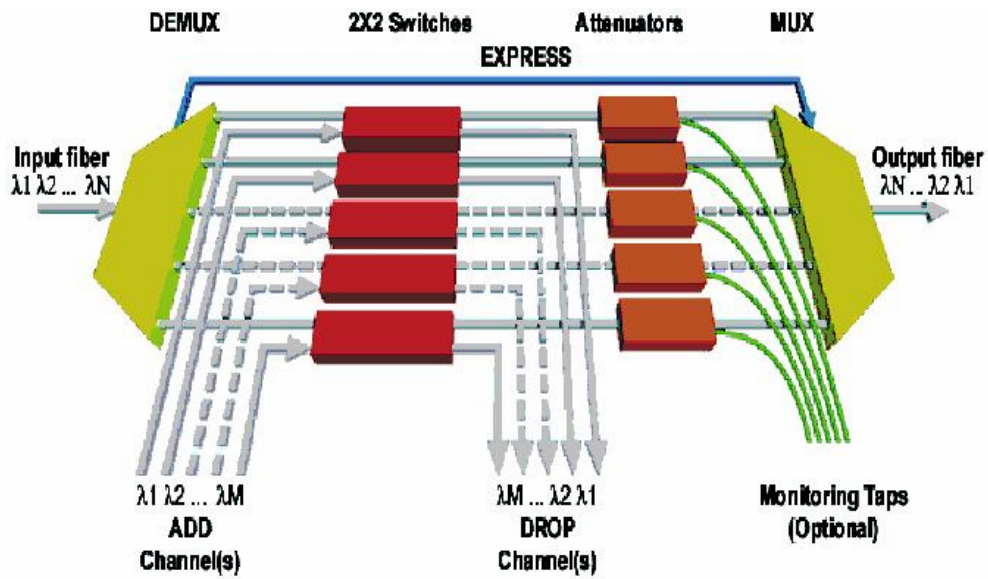

Figure 1-5 A Reconfigurable Optical Add-Drop Multiplexer [13]

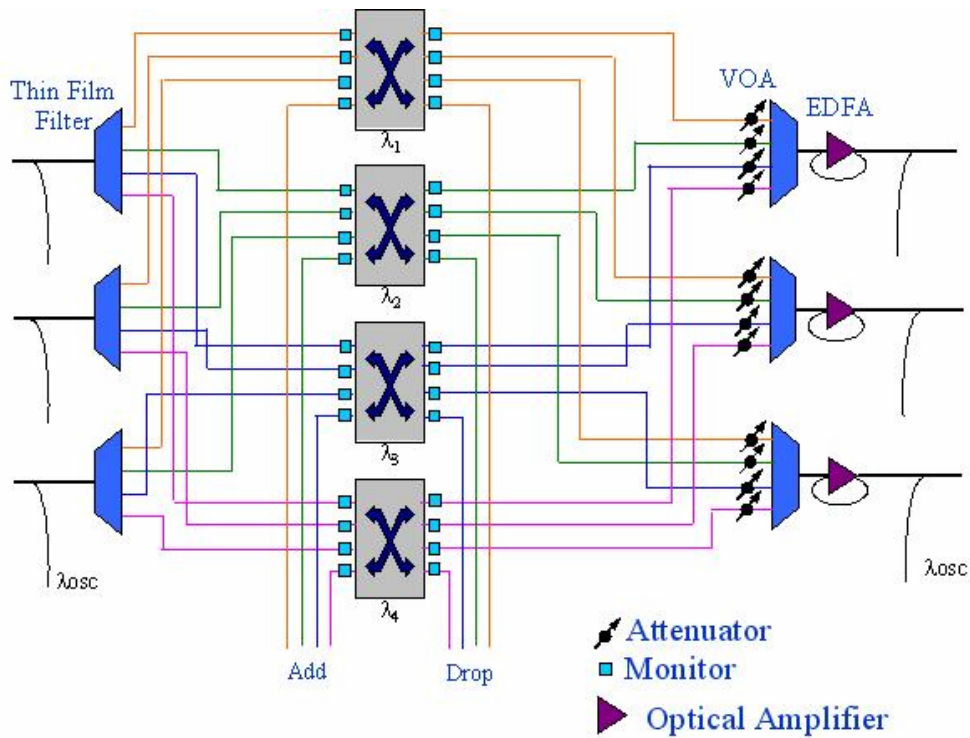

Figure 1-6 A Optical Cross-Connect [13]

An OXC (optical cross-connect) not only drops and adds lambdas, but also switches lambdas from an input fiber to a different output fiber. In Figure 1-6, there are 3 fibers connected to the switch, each with four lambdas. Therefore, we need four four-port lambda switches and a total of sixteen ports for input fibers inside this

OXC. Any lambda from the three input fibers can be switched to a different output fiber. However, note that that each lambda can only be directed to any output fiber once, which means that the same lambda from different input fibers must be switched to an output fiber exactly once.

The lambda switch inside the OXC can be a space switch, such as a 2-D MEMS (micro-electro-mechanical) space switch, as shown in Figure 1-7. Each wavelength can be directed to a different output port by the active mirror. A 2-D MEMS needs N^2 mirrors (switches), where N is the number of input ports. In the latest technology of DWDM, each fiber can carry 273 lambdas. Therefore, the OXC has become extremely complex with 74,529 mirrors inside each lambda switch. As the complexity of the 2-D MEMS switch design is proportional to N^2 , it is not scalable to switches with a large number of ports.

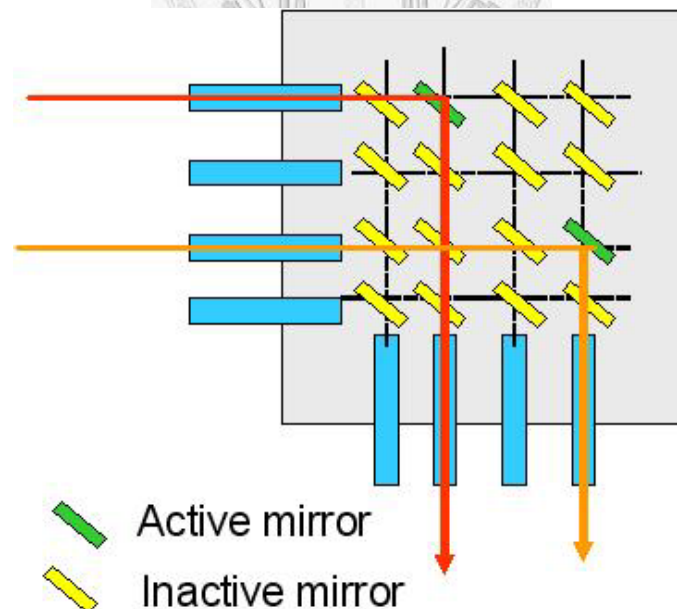

Figure 1-7 2-D MEMS Space switch

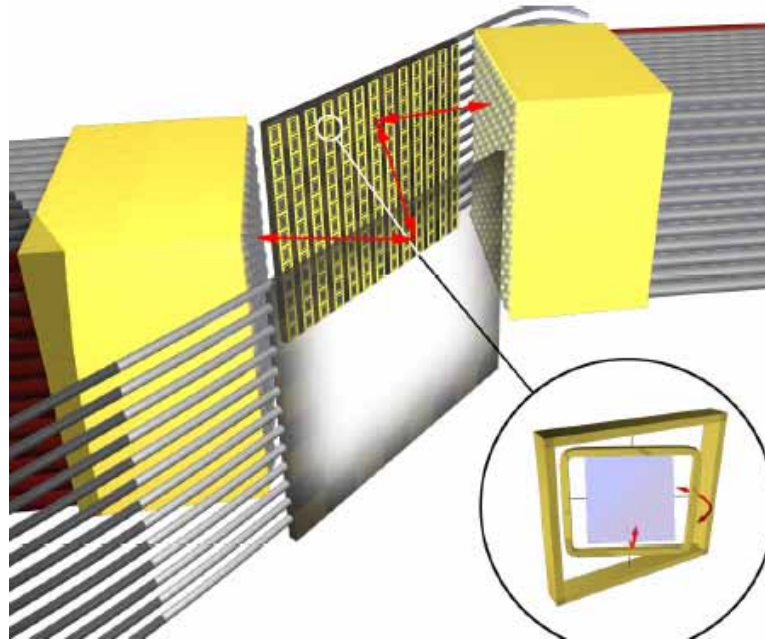

Figure 1-8 3-D MEMS Switch

In recent research, another switch technology, shown in Figure 1-8, uses two arrays of mirrors that rotate on two axes. Each input fiber directs light to a mirror in the input array. The input mirror steers the input optical beam to any output mirror, and each output mirror directs light to an output fiber. This topology is called a 3-D MEMS switch, because the optical beams are switched in the three-dimensional space between the two MEMS die [15]. A 3-D switch configuration needs only $2N$ mirrors, which is far fewer than the N^2 mirrors required by 2-D MEMS. However, due to the difficulty of building flat, thin-film mirrors, which would make the optical loss lower while the mirrors rotate frequently, the number of ports of 3-D MEMS is still limited to around 50-200.

In future, photonic switches will have the potential to change the way optical networks are built and used, because large photonic switches can be built with a 3-D topology and bulk-silicon MEMS structures. Photonic switches with 256 ports and a mean optical loss of 1.3 dB have already been demonstrated, so multi-stage switches could form the basis of larger switches [15].

1.1.3 GMPLS

GMPLS (General Multi-Protocol Label Switching) [1], shown in Figure 1-9, is a unified, open, standard control plane. It is an extension of MPLS (Multi-Protocol Label Switching) and defines a more general control plane. GMPLS defines the Lambda switch capable (LCS) interface and fiber switch capable (FSC) interface that support fiber and wavelength layer transmission.

Due to the rapid development of DWDM, the optical cross connect may not afford the intense traffic of fibers by wavelength routing. A waveband switch capable (WBSC) interface is proposed by [2], whereby several wavelengths are grouped as a waveband. For example, if a fiber can carry 20 lambdas, we let 10 wavelengths group as a waveband so that there are 20 wavebands. If we deploy a waveband switch at this OXC node, we only need 20 input ports, instead of 200. The waveband label should be inserted between the wavelength routing layer and the fiber routing layer, as shown in Figure 1-9. Although wavelength routing is the most flexible routing method when compared with waveband routing and fiber routing, it incurs the most complex and most expensive OXC (most number of ports).

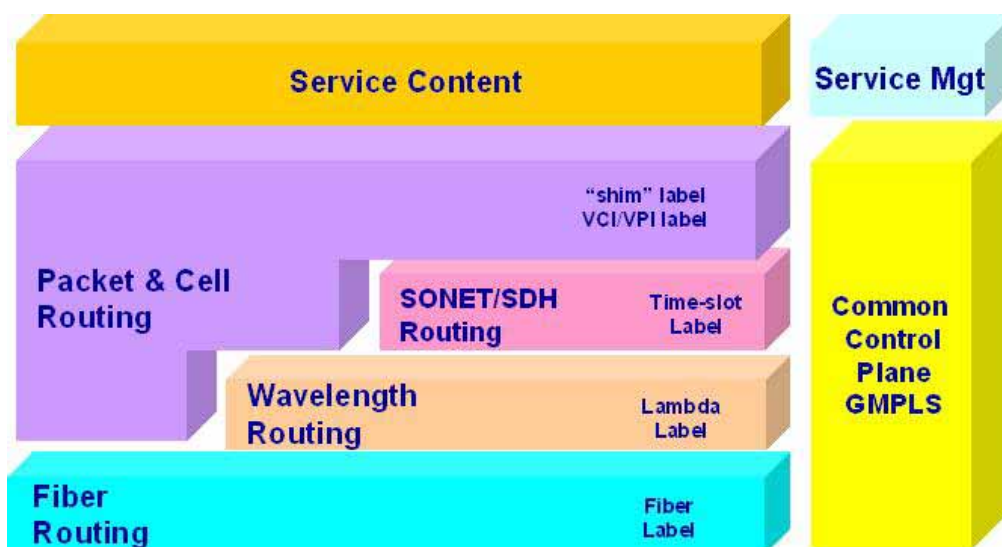

Figure 1-9 GMPLS Control Plane

1.2 Motivation

Due to the tremendous increase of fiber link capacity, each fiber can carry hundreds of lambda. However, the optical cross-connect tends to be much more complicated, and sometimes the OXC can not even handle the traffic.

GMPLS and its extension, described in Section 1.1.3, define three kinds of switching device: FSC, WBSC, and LSC. The FSC (fiber switch capable) is the most cost effective, but it is inflexible because all the traffic within the same fiber must be switched all together. In Figure 1-10, the first fiber is switched to the n^{th} fiber. The WBSC (waveband switch capable) is also much cheaper than LSC, and has better flexibility than FSC, because the traffic is switched by waveband allowing wavelengths in the same waveband to be switched simultaneously. For example, in Figure 1-11, the first waveband of the first fiber is switched to the first waveband of second fiber. Although the LSC (lambda switch capable) is the most expensive, because a lot of ports are needed, it is the most flexible switching device. Each wavelength can be switched to a different output fiber. For example, in Figure 1-12, the λ_0 from Fiber₀ is switched to the same output fiber₀. However the λ_{99} from Fiber₀ is switched to the Fiber₉.

Since the cost of a lambda switch is extremely high, it's not feasible to let all the switch nodes be lambda switches like all the traditional routing and wavelength assignment problems in the literature (see Section 1.3.1). Therefore, how to effectively allocate the three kinds of switches in a heterogeneous WDM optical network becomes important. To the best of my knowledge, there has not been any research into this problem, but the issue should become increasingly important as

WDM technology improves. This thesis contributes a great deal to network design and planning in heterogeneous networks.

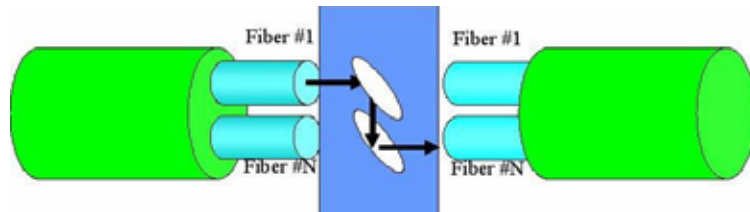

Figure 1-10 Fiber switch

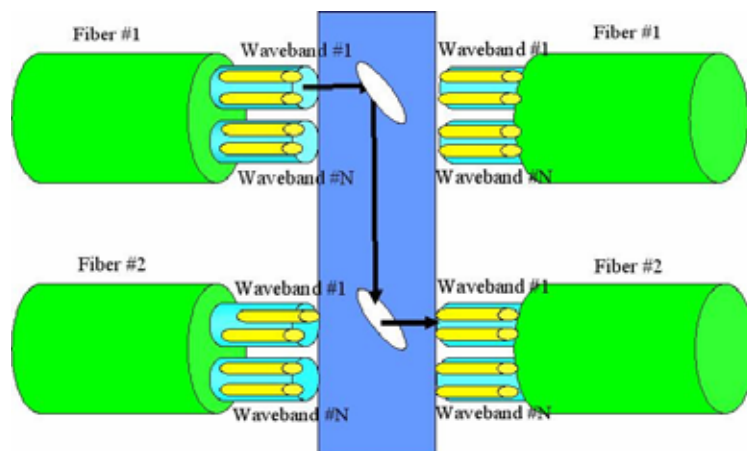

Figure 1-11 Waveband switch

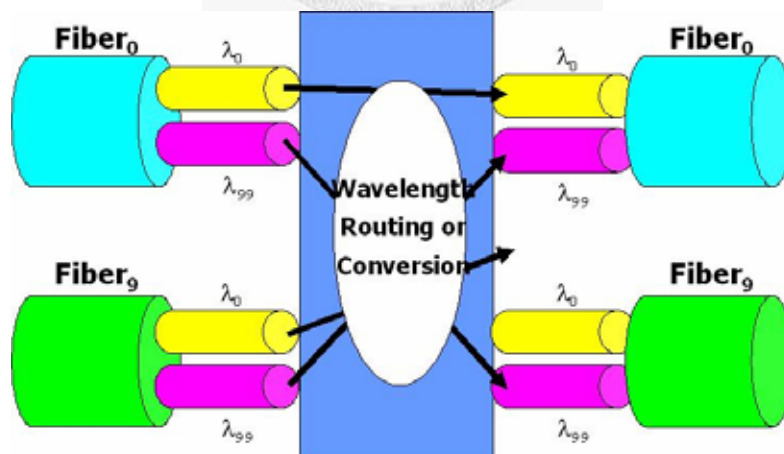

Figure 1-12 Wavelength (λ) switch

1.3 Literature Survey

1.3.1 RWA Related Issues

Although many papers discuss the RWA (routing and wavelength assignment) problem in a WDM optical network, most of them focus on a wavelength switching capable interface. Hence, these works are not applicable in DWDM technology today.

In [3], the RWA related issue is classified in three dimensions as follows:

©Type of switch node:

- ☆ Homogenous network: In the optical WDM network, all the nodes are hierarchical, which means that a waveband can be set up at any switch node, and can be decomposed at any switch node.
- ☆ Heterogeneous network: In the optical WDM network, not all the nodes are hierarchical, which means that the fiber traffic can only be switched by waveband at specific nodes with a waveband switching capable interface. The traffic only can be switched by fiber at specific nodes with a fiber switching capable interface.

©Routing Models

- ☆ Integrated routing: The routes are computed for both the wavelength and waveband paths simultaneously. This routing model is more effective, but the algorithm or formulation tends to be more complicated.
- ☆ Separate routing: First, the routes for the wavelength are computed, and then the routes for the waveband are computed. It is basically a two-stage computation. Therefore, the algorithm of this model is much simpler than integrated routing, but it is not as effective.

©Routing Occasion

- ☆ Online routing: The traffic of a network is dynamic. Each time a new demand for any source-destination pair occurs, the route and the assigned wavelength of this demand are computed at once. This can handle dynamic traffic well.
- ☆ Offline routing: Given the traffic demand of all the source-destination pairs, the optimal routes are computed at the beginning of the process. This assumes that the traffic of the network will be stable for a period of time.

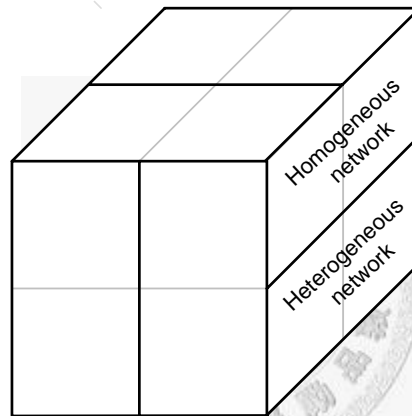

Figure 1-13 Three dimensions of the RWA related issues. [3]

Figure 1-13 shows the diagram of the three dimensions. In the next section, we focus on homogeneous and heterogeneous networks, and discuss existing works. Note that since the traditional RWA problem has already been proved to be an NP-hard problem, related issues containing the RWA problem are also NP-hard problems.

1.3.2 Homogeneous Network

All the switch nodes in a homogeneous network are hierarchical, and can set up wavebands or decompose wavebands to wavelengths. Hence, [4] developed the

architecture of MG-OXC (Multigranularity Optical Cross-Connect), shown in the Figure 1-14. If the input fiber goes through the fiber cross-connect, it can be switched to any output fiber. Some input fibers might go through the FTB (fiber to waveband) port, and be demultiplexed as wavebands. If the waveband goes through the waveband cross-connect, it can be switched and multiplexed as a fiber and then go to the BTF (waveband to fiber) port. Again, some wavebands might go through the BTW (waveband to wavelength) port, and be demultiplexed as wavelengths. If the wavelength goes through the wavelength cross-connect, it can be switched and multiplexed as a waveband and then go to the WTB (wavelength to waveband) port. Note that in wavelength cross-connects, some wavelengths might be dropped, and some might be added.

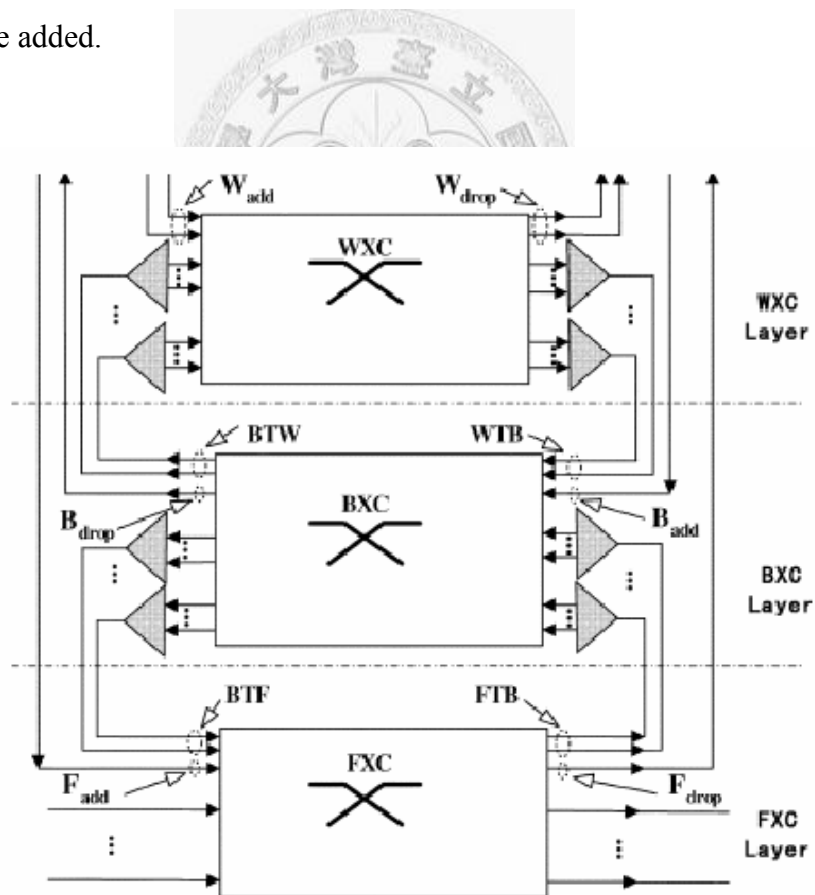

Figure 1-14 Multigranularity Optical Cross-Connect [4]

In [3], the authors develop both an online and an offline routing and wavelength assignment heuristic algorithm by separate routing methods.

In [4] with static traffic (offline routing), in order to minimize the total cost, the authors try to minimize the total port counts or minimize the maximum port counts of MG-OXC (including FXC, BXC, and WXC layer), shown in Figure 1-14. They propose an integer linear programming formulation, but they do not solve it. Instead, they propose a separate routing heuristic algorithm to deal with this problem, and claim a near-optimal solution quality. The heuristic algorithm has three stages: balanced path routing, wavelength assignment, and waveband switching. Since the proposed integer linear programming formulation is too complicated, the heuristic algorithm still uses a separate routing method, but it still has some limitations compared to the integrated routing method. However, an integrated routing algorithm is relatively difficult to design.

In [5], the authors develop a heuristic algorithm with dynamic traffic in order to minimize the port counts of MG-OXC and keep the blocking probability at an acceptable level. Note that the authors assume that the demultiplexing proportion of fiber-to-waveband and waveband-to-wavelength is fixed at each node, so it is not a very flexible method. In addition, they only conduct an experiment with a simple network with one fiber incident to every node; however the algorithm should be tested in a more complicated network.

The authors of [6] also propose an MG-OXC architecture to reduce costs and effectively utilize resources. They also designed two RWA heuristic algorithms, namely, dynamic tunnel allocation (DTA) and capacity-balanced static tunnel allocation (CB-STA) that take both online routing and offline routing into consideration.

[16] extends the work of [6]. The authors develop a formulation for a situation where traffic increases in order to effectively design MG-OXCs. This formulation can be simplified as two integer programming problems, and solved by optimization techniques. This is the first paper that tries to solve this problem with mathematical models. However, here the authors divide the formulation into two IP problems, which weakens to the original optimal solution.

1.3.3 Heterogeneous Network

There are very few related works on heterogeneous networks. [8] focuses on a heterogeneous network with static traffic. It proposes an integer programming formulation for routing and wavelength assignment and solves it by Lagrangean relaxation with a heuristic. The objective function is to minimize the most congested link. It assumes there are three kinds of switches: fiber capable, waveband capable, and lambda capable.

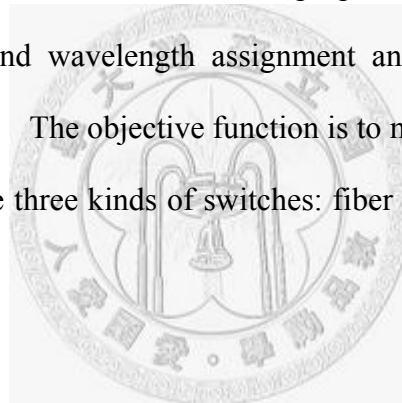

To the best of my knowledge, this work is the only paper that discusses RWA in heterogeneous networks. Therefore, our work contributes a great deal to network design and planning in heterogeneous networks.

1.3.4 Lagrangean Relaxation

In the 1970s, Lagrangean Relaxation was first proposed to deal with the large scale linear programming problem. Later, it was found that Lagrangean Relaxation also performed excellently in integer programming problems and even nonlinear programming problems.

When applying Lagrangean relaxation, the complicated constraints of the original hard problems can be properly relaxed. After dualizing the side constraints with multipliers to the objective function, the original problem becomes an easier Lagrangean problem. This new problem can then be divided into several independent subproblems with its constraints. Therefore, we only need to solve each subproblem by specific algorithms or exhaustive search within a smaller space. Since we relax some constraints of the original problem, the optimal value we find in the Lagrangean problem is a legitimate lower (upper) bound for a minimization problem (maximization problem).

However, the bound we find in the Lagrangean problem might violate some relaxed constraints in the original problem. Hence, it may not be a feasible solution after all, as we need to develop a heuristic algorithm to find an upper (lower) bound of the original problem. The bound should be a feasible solution to the original problem. By taking advantage of the multipliers originated in the Lagrangean problem, we can develop a relatively good heuristic algorithm to find a tighter bound in the feasible region.

In each iteration after finding the lower and upper bounds, we hope to find the tightest lower bound and upper bound. In order to find the tightest bounds, the multipliers solved in the Lagrangean problem are important. Although there are many ways to solve it, we adopt the subgradient method because it properly adjusts the parameters used for each iteration. The Lagrangean relaxation process is shown as in Figure 1-15.

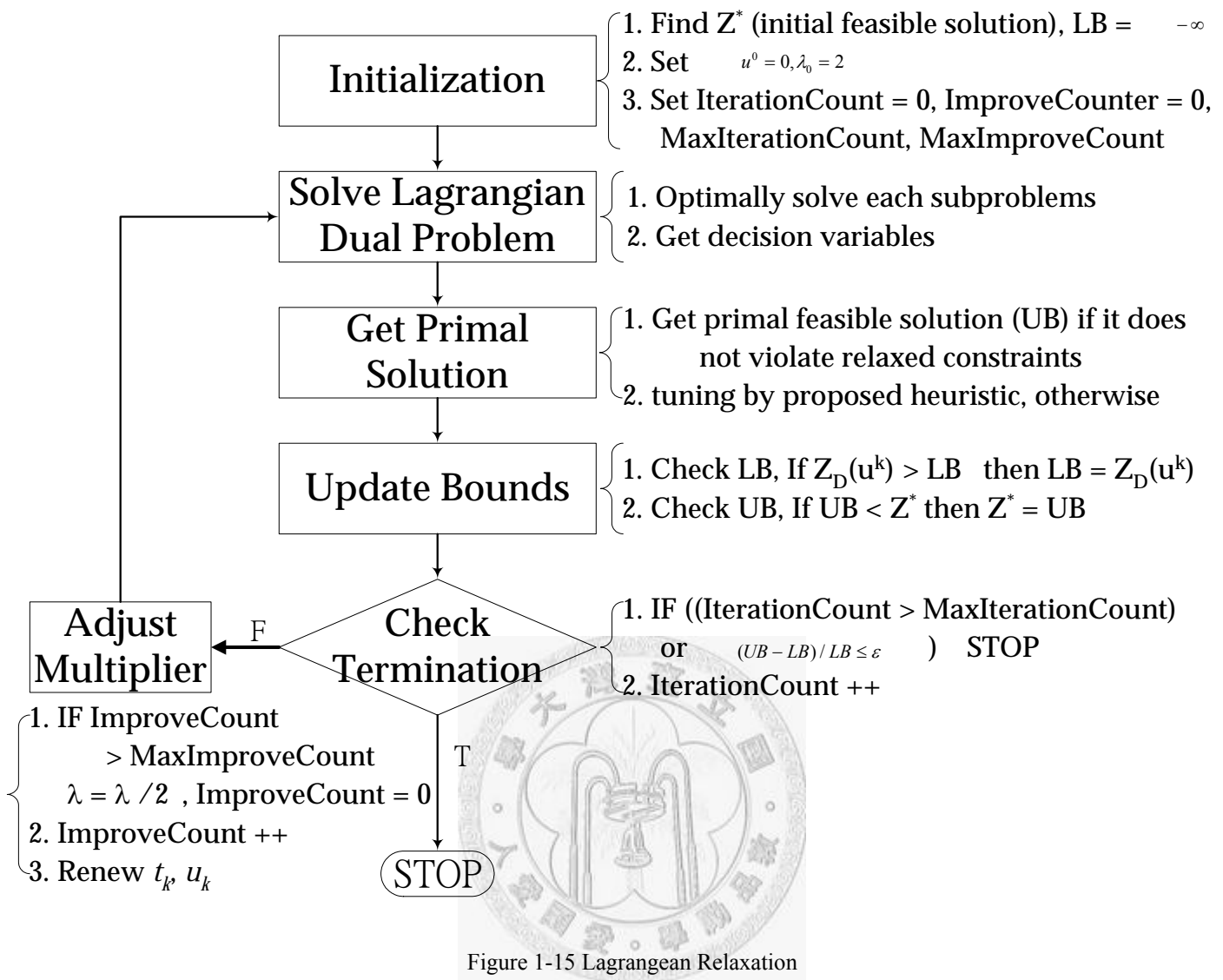

1.4 Thesis Organization

In Chapter 2, we propose the problem formulation. In addition, the related notations and the graph transformation are also described. In Chapter 3, the solution approach to this problem is presented. In chapter 4, the getting primal feasible solution is proposed. We also develop a simple heuristic algorithm here for comparison with LR solution quality. The numerical experiment is described in Chapter 5. Finally, in chapter 6, we present our conclusions and indicate the direction of future work.



Chapter 2 Problem Formulation

2.1 Problem Description

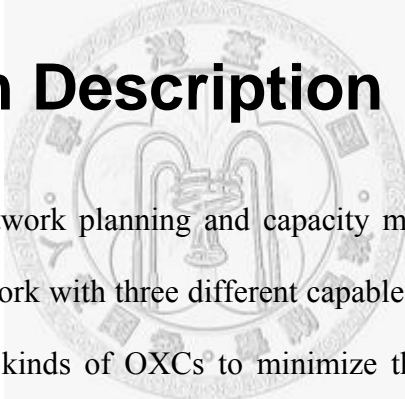

This is an optical network planning and capacity management problem. In a heterogeneous WDM network with three different capable OXC (FSC, WBSC, LSC), how to allocate the three kinds of OXCs to minimize the total cost is the task of network planning. The output result of the problem must determine the routing and wavelength assignment of all the source-destination traffic demands. This is referred to as capacity management. Therefore, the RWA problem is part of our problem. Since the RWA problem has been proved to be NP-hard problem, the problem is also NP-hard.

In [3], this problem belongs to integrated offline routing in a heterogeneous network. We focus on a heterogeneous network because it is not necessary for each node to be hierarchical which is more expensive. We believe that compared to a homogeneous network, a heterogeneous network can utilize resources better and is

more cost effective.

Table 2-1 The assumptions, objective, and constraints

Assumptions
<ol style="list-style-type: none">1. There are three kinds of switches: fiber switch capable, waveband switch capable, and lambda switch capable.2. All the traffic demands between source-destination pairs are static.3. There is no wavelength or waveband conversion capability.
Given
<ol style="list-style-type: none">1. Network topology, including node set and link set.2. The traffic demand between each source-destination.3. The number of wavelengths a fiber can carry.4. The number of wavebands a fiber can be divided into.5. The cost functions of the three switches.
Objective
To minimize the total cost.
Subject to
<ol style="list-style-type: none">1. Wavelength continuity.2. Traffic demands.3. Each link carries every lambda only once.4. Each node installs only one kind of switch.

Output Results

1. The kind of switch installed at each node.
2. All the paths with specific wavelengths between source-destination pairs are chosen.
3. Whether all the links with specific wavelength are chosen, or not.

2.2 Graph Transformation

Before formulating this problem, we need to apply a graph transformation (shown in Figure 2-1) in order to model the problem as an integer programming problem properly. First, we split each node into two-layer phantom nodes. The left side first layer phantom nodes accept the incoming fibers (IF), and each node accepts one fiber link. The right side first layer phantom nodes send the traffic to outgoing fibers (OF), and each node sends to one fiber link. There are three kinds of second layer phantom nodes which are for fiber switches, waveband switches and lambda switches.

Figure 2-1 shows that if a fiber switch is installed, a_l is set to 1, and the second layer phantom links, d_l , between second layer phantom nodes must be appropriately assigned in order to match all the second layer input and output phantom nodes. Similarly, if a waveband switch is installed, b_l is set to 1, and the second layer phantom links, e_l , between second layer waveband phantom nodes (each waveband layer) must be appropriately assigned in order to match all the second layer input and output phantom nodes. If a lambda switch is installed, all the first layer phantom nodes construct the link to the second layer lambda switch phantom nodes, which

means c_i is set to 1. In Figure 2-1, there are three input fibers and three output fibers. After the graph transformation, we can appropriately model this problem as an integer programming problem, as shown in section 2.4.

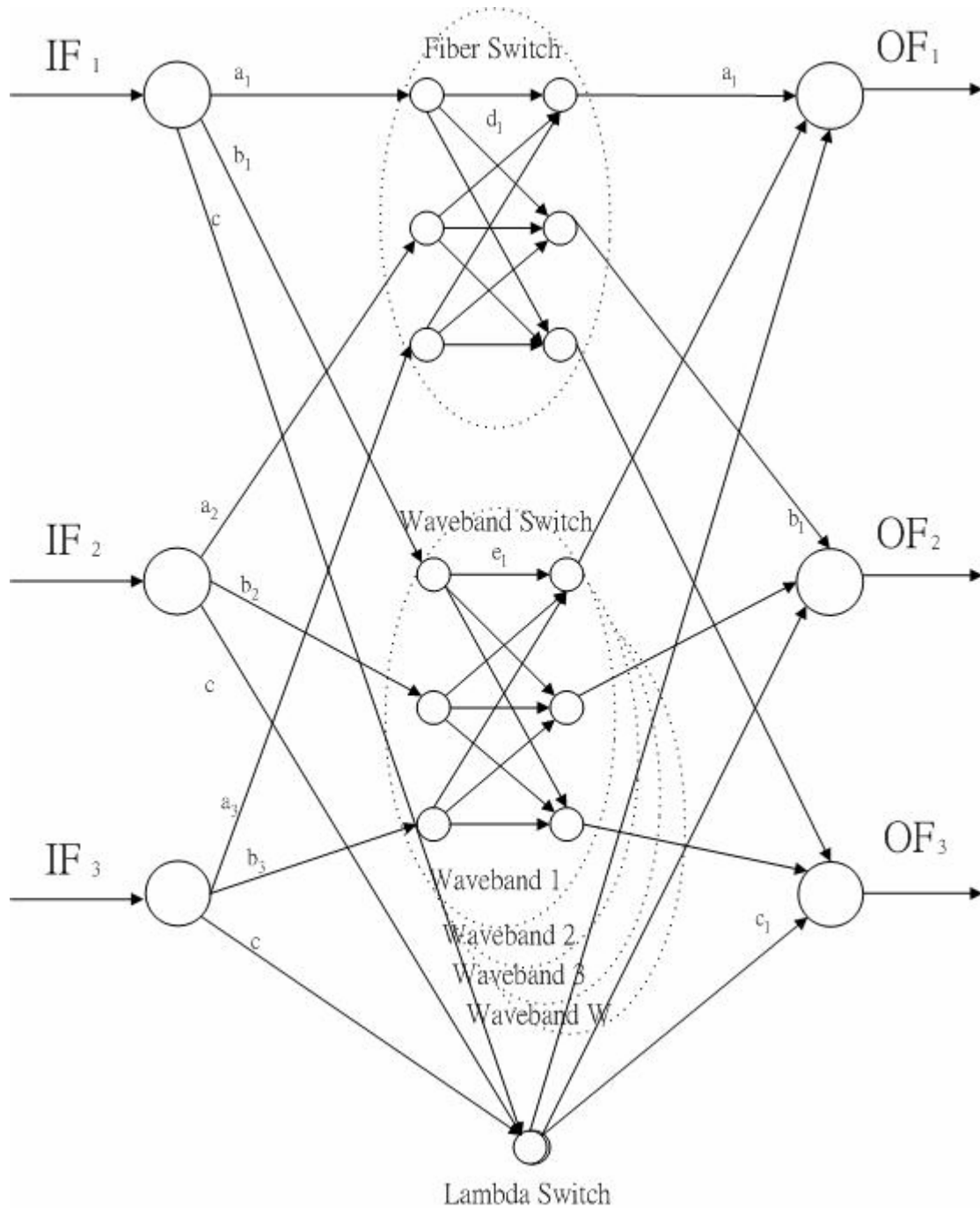

Figure 2-1 Graph Transformation

2.3 Notation

Here we give notations of the formulation, including the input parameters and decision variables shown in Table 2-2 and table 2-3:

Table 2-2 Input Parameters

Input Parameters	
Notation	Description
N	the set of switch nodes in the network
L	the set of physical optical links
\bar{F}	the maximum number of fibers incident to a switch node
L^{F_a}	the set of first layer FSC phantom links within a switch node
L^{F_b}	the set of first layer WSC phantom links within a switch node
L^{F_c}	the set of first layer LSC phantom links within a switch node
L^{S_a}	the set of second layer FSC phantom links within a switch node
L^{S_b}	the set of second layer WSC phantom links within a switch node
Y_n^{in}	the set of first layer phantom input nodes of switch node n
Y_n^{out}	the set of first layer phantom output nodes of switch node n
V_n^{in}	the set of second layer phantom input nodes for switch node n
V_n^{out}	the set of second layer phantom output nodes for switch node n
J	the set of wavelengths on each link (assumed to be the same for all links)
$ J $	the number of wavelengths
W	the set of origin-destination (OD) pairs requesting lightpath set-up
$ B $	the number of wavelengths in a waveband
W_n	the set of OD pairs originating at source node n

S_n	the set of OD pairs where node n is the source node
B_n	the set of wavebands of WSC node n
P_w	The candidate path set of an OD-pair w
λ_w	lightpath demand of an OD-pair w
δ_{pl}	1, if path p includes link l ; 0, otherwise
τ_{lj}	1, if wavelength j belongs to the phantom link l ; 0, otherwise
θ_{lb}	1, if link l is belongs to waveband b ; 0, otherwise
σ_{lv}	1, if link l is incident to node v ; 0, otherwise
$\Psi_n(F_n)$	the cost function of installing FSC at switch node n ;
$\Omega_n(Z_n)$	the cost function of installing WSC at switch node n ;
$\Phi_n(U_n)$	the cost function of installing LSC at switch node n ;

Table 2-3 Decision Variables

Decision Variables	
Notation	Description
x_{pj}	1, if lightpath p uses wavelength j ; =0, otherwise
a_l	1, if the first layer phantom FSC link, l , is selected; =0, otherwise
b_l	1, if the first layer phantom WSC link, l , is selected; =0, otherwise
c_l	1, if the first layer phantom LSC link, l , is selected; =0, otherwise
F_n	1, if FSC is installed at node n ; =0, otherwise
Z_n	1, if WSC is installed at node n ; =0, otherwise
U_n	1, if LSC is installed at node n ; =0, otherwise
d_l	1, if the second layer phantom FSC link l is selected; =0, otherwise
e_l	1, if the second layer phantom WSC link l is selected; =0, otherwise

2.4 Problem Formulation

Problem (P):

$$\text{Min } \sum_{n \in N} (\Psi_n(F_n) + \Omega_n(Z_n) + \Phi_n(U_n)) \quad (\text{L.R.})$$

subject to:

$$\sum_{p \in P_w} \sum_{j \in J} x_{pj} = \lambda_w \quad \forall w \in W \quad (1)$$

$$\sum_{w \in W} \sum_{p \in P_w} x_{pj} \delta_{pl} \leq 1 \quad \forall j \in J, l \in L \quad (2)$$

$$x_{pj} = 0 \text{ or } 1 \quad \forall j \in J, p \in P_w, w \in W \quad (3)$$

$$F_n + Z_n + U_n = 1 \quad \forall n \in N \quad (4)$$

$$F_n = 0 \text{ or } 1 \quad \forall n \in N \quad (5)$$

$$Z_n = 0 \text{ or } 1 \quad \forall n \in N \quad (6)$$

$$U_n = 0 \text{ or } 1 \quad \forall n \in N \quad (7)$$

$$\sum_{w \in W} \sum_{p \in P_w} x_{pj} \delta_{pl} \leq a_l \quad \forall j \in J, l \in L^a \quad (8)$$

$$\sum_{w \in W} \sum_{p \in P_w} x_{pj} \delta_{pl} \leq b_l \quad \forall j \in J, l \in L^b \quad (9)$$

$$\sum_{w \in W} \sum_{p \in P_w} x_{pj} \delta_{pl} \leq c_l \quad \forall j \in J, l \in L^c \quad (10)$$

$$a_l \sigma_{lv} = F_n \quad \forall l \in L^a, v \in Y_n^{in} \cup Y_n^{out}, n \in N \quad (11)$$

$$b_l \sigma_{lv} = Z_n \quad \forall l \in L^b, v \in Y_n^{in} \cup Y_n^{out}, n \in N \quad (12)$$

$$c_l \sigma_{lv} = U_n \quad \forall l \in L^c, v \in Y_n^{in} \cup Y_n^{out}, n \in N \quad (13)$$

$$a_l = 0 \text{ or } 1 \quad \forall l \in L^a \quad (14)$$

$$b_l = 0 \text{ or } 1 \quad \forall l \in L^b \quad (15)$$

$$c_l = 0 \text{ or } 1 \quad \forall l \in L^c \quad (16)$$

$$\sum_{w \in W} \sum_{p \in P_w} x_{pj} \delta_{pl} \leq d_l \quad \forall j \in J, l \in L^{S_a} \quad (17)$$

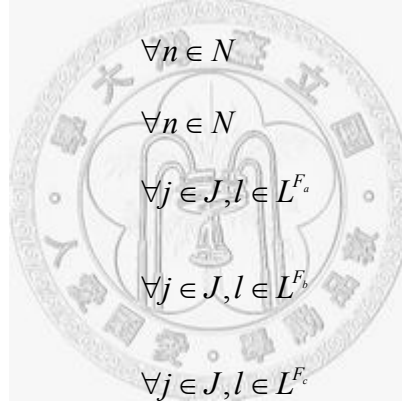

$$\sum_{l \in L^{S_a}} d_l \sigma_{lv} = F_n \quad \forall v \in V_n^{in}, n \in N \quad (18)$$

$$\sum_{l \in L^{S_a}} d_l \sigma_{lv} = F_n \quad \forall v \in V_n^{out}, n \in N \quad (19)$$

$$\sum_{w \in W} \sum_{p \in P_w} x_{pj} \delta_{pl} \leq e_l \tau_{lj} \quad \forall j \in J, l \in L^{S_b} \quad (20)$$

$$\sum_{l \in L^{S_b}} e_l \theta_{lb} \sigma_{lv} = Z_n \quad \forall b \in B_n, v \in V_n^{in}, n \in N \quad (21)$$

$$\sum_{l \in L^{S_b}} e_l \theta_{lb} \sigma_{lv} = Z_n \quad \forall b \in B_n, v \in V_n^{out}, n \in N \quad (22)$$

$$d_l = 0 \text{ or } 1 \quad \forall l \in L^{S_a} \quad (23)$$

$$e_l = 0 \text{ or } 1 \quad \forall l \in L^{S_b} \quad (24)$$

$$\sum_{p \in P_w} x_{pj} \delta_{pl} \leq 1 \quad \forall w \in W, j \in J, l \in L \cup L^{F_a} \cup L^{F_b} \cup L^{F_c} \cup L^{S_a} \cup L^{S_b}. \quad (25)$$

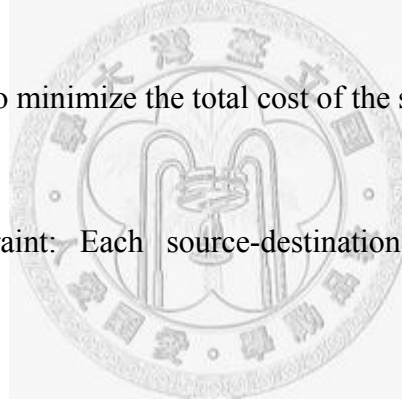

The objective function is to minimize the total cost of the switch nodes.

Constraint (1):

The capacity constraint: Each source-destination traffic demand must be satisfied.

Constraint (2):

Each wavelength can be used at most once on each link.

Constraints (8), (9), (10), (17), (20):

They impose the limit that if the link is chosen, then the wavelength at each chosen link can be selected at most once.

Constraint (4):

Each switch node must use one of the three OXCs.

Constraint (3):

Each link can only either select the wavelength or not.

Constraints (5), (6), (7):

At each node n , the OXC can either be selected or not.

Constraints (14), (15), (16):

In the routing decision, the first layer phantom links can either be selected or not.

Constraints (23), (24):

In the routing decision, the second layer phantom links can either be selected or not.

Constraints (11), (12), (13):

If an OXC is selected, the corresponding first layer phantom links must also be selected (set as 1).

Constraints (18), (19):

If a fiber switch is installed at the switch node, the second layer phantom links (d_i) between the fiber switch's second layer phantom nodes must be properly chosen to match all the input and output phantom nodes. In other words, exactly one link will be incident to either the input or output phantom nodes if the fiber switch is installed. Otherwise, no phantom links should be selected.

Constraints (21), (22):

If a waveband switch is installed at the switch node, the second layer phantom links (e_i) between the waveband switch's second layer phantom nodes must be properly chosen to match all the input and output phantom nodes. In other words, exactly one link will be incident to either the input or output phantom nodes if the fiber switch is installed. Otherwise, no phantom links should be selected.

Constraint (25):

This is a redundant constraint that does not influence the result; however it can limit the solution space when solving the subproblems.

Chapter 3 Solution Approach

3.1 Lagrangean Relaxation

We relax Constraints (2), (8), (9), (10), (17), and (20) constraints and multiply them by the multiplier vectors $q, r, s, t, u,$ and v respectively, which adds to the objective function as follows:

$$\begin{aligned}
 & Z_d(q, r, s, t, u, v) \\
 = & \text{Min} \left[\sum_{n \in N} (\Psi_n(F_n) + \Omega_n(Z_n) + \Phi_n(U_n)) \right. \\
 & + \sum_{l \in L} \sum_{j \in J} q_{lj} \left(\sum_{w \in W} \sum_{p \in P_w} x_{pj} \delta_{pl} - 1 \right) + \sum_{l \in L^a} \sum_{j \in J} r_{lj} \left(\sum_{w \in W} \sum_{p \in P_w} x_{pj} \delta_{pl} - a_l \right) \\
 & + \sum_{l \in L^b} \sum_{j \in J} s_{lj} \left(\sum_{w \in W} \sum_{p \in P_w} x_{pj} \delta_{pl} - b_l \right) + \sum_{l \in L^c} \sum_{j \in J} t_{lj} \left(\sum_{w \in W} \sum_{p \in P_w} x_{pj} \delta_{pl} - c_l \right) \\
 & \left. + \sum_{l \in L^d} \sum_{j \in J} u_{lj} \left(\sum_{w \in W} \sum_{p \in P_w} x_{pj} \delta_{pl} - d_l \right) + \sum_{l \in L^e} \sum_{j \in J} v_{lj} \left(\sum_{w \in W} \sum_{p \in P_w} x_{pj} \delta_{pl} - e_l \tau_{lj} \right) \right]
 \end{aligned}$$

subject to (1), (3)~(7), (11)~(16), (18), (19), (21)~(25).

3.2 Subproblem

After a proper rearrangement of the formulation, it becomes:

$$Z_D(q, r, s, t, u, v)$$

$$\begin{aligned}
&= \text{Min} \left\{ \sum_{j \in J} \sum_{w \in W} \sum_{p \in P_w} \left(\sum_{l \in L} q_{lj} \delta_{pl} + \sum_{l \in L^a} r_{lj} \delta_{pl} + \sum_{l \in L^b} s_{lj} \delta_{pl} + \sum_{l \in L^c} t_{lj} \delta_{pl} + \sum_{l \in L^a} u_{lj} \delta_{pl} + \sum_{l \in L^b} v_{lj} \delta_{pl} \right) x_{pj} \right. \\
&\quad + \sum_{n \in N} (\Omega_n(Z_n) + \Psi_n(F_n) + \Phi_n(U_n)) \\
&\quad \left. - \left(\sum_{j \in J} \left(\sum_{l \in L^a} r_{lj} a_l + \sum_{l \in L^b} s_{lj} b_l + \sum_{l \in L^c} t_{lj} c_l + \sum_{l \in L^a} u_{lj} d_l + \sum_{l \in L^b} v_{lj} e_l \tau_{lj} \right) \right) - \sum_{j \in J} \sum_{l \in L} q_{lj} \right\}
\end{aligned}$$

subject to (1), (3)~(7), (11)~(16), (18), (19), (21)~(25).

We can divide $Z_D(q, r, s, t, u, v)$ into two independent subproblems including their constraints.

3.2.1 Subproblem 1

$$\begin{aligned}
&Z_{sub3.1}(q, r, s, t, u, v) \\
&= \text{Min} \sum_{j \in J} \sum_{w \in W} \sum_{p \in P_w} \left(\sum_{l \in L} q_{lj} \delta_{pl} + \sum_{l \in L^a} r_{lj} \delta_{pl} + \sum_{l \in L^b} s_{lj} \delta_{pl} + \sum_{l \in L^c} t_{lj} \delta_{pl} + \sum_{l \in L^a} u_{lj} \delta_{pl} + \sum_{l \in L^b} v_{lj} \delta_{pl} \right) x_{pj}
\end{aligned} \tag{SUB 3.1}$$

subject to

$$\sum_{p \in P_w} \sum_{j \in J} x_{pj} = \lambda_w \quad \forall w \in W \tag{3.1}$$

$$x_{pj} = 0 \text{ or } 1 \quad \forall j \in J, p \in P_w, w \in W \tag{3.2}$$

$$\sum_{p \in P_w} x_{pj} \delta_{pl} \leq 1 \quad \forall w \in W, j \in J, l \in L \cup L^a \cup L^b \cup L^c \cup L^a \cup L^b. \tag{3.3}$$

For x_{pj} , it can be decomposed into $|W|$ independent subproblems, and each of which can be solved by the shortest path algorithm and the Surballe's Link Disjoint K-shortest path algorithm [9], [10]. For each OD-pair, we calculate the shortest path cost of each wavelength. For the lightpath demand of each OD-pair, we calculate all the marginal costs of k+1 link disjoint shortest path of each wavelength (k is the current lightpath we find), and pick the smallest one as this lightpath demand cost.

The algorithm stops once we find enough traffic demand. Our algorithm is shown as Table 3-1, and the proof is given in Table 3-2.

The complexity of the k -shortest path algorithm for each iteration (to find one more lightpath) is $n^2 \log n$. Hence, the complexity of the k -shortest path algorithm is n^2 (shortest path algorithm) plus $(k-1)n^2 \log n$. In the worst case, where the k lightpaths are chosen by the same wavelength, we must run $[1+2+3+\dots+(k-1)]$ iterations. Therefore, for each OD-pair, w , the time complexity becomes $O(|J|n^2 + k^2 n^2 \log n)$. Note that n is the number of phantom nodes in the topology, and is proportional to the number of physical links; $|J|$ is the number of wavelengths a fiber can carry; and k is the number of lightpaths of this OD-pair's total traffic demand.

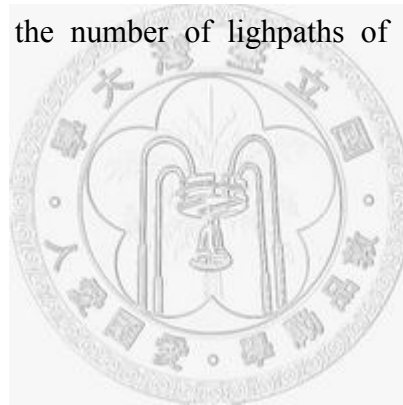

Table 3-1 Find the minimum cost of K lightpaths for each OD-pair

```

Algorithm Min_K_Lightpath
begin
  for each wavelength  $j \in J$  do
    begin
      run Dijkstra's-shortest-path on each wavelength layer  $x_j^1$ ;
      do  $np_j := 0$ ; /* num-disjoint-path on each wavelength set to zero */
    end;
    for each wavelength  $j \in J$  do
      find the minimum  $x_j^1, np_j := 1$ ;
    end;
    repeat
      for wavelenth  $j := 1$  to  $J$  do
        begin
          if  $np_j > 0$  then
            begin
              run Link-Disjoint-k-shortest-path on wavelength  $j$  to
              calculate  $x_j^{np_j+1}$ ;
            end;
          for each wavelength  $j \in J$  do
            begin
              find the minimum  $x_j^{np_j+1} - x_j^{np_j}$ 
               $np_j := np_j + 1$ ;
            end;
          until all traffic demand of OD pair  $w$ ,  $\lambda_w$  is satisfied
        end.
    end.

```

Table 3-2 The proof of Min_K_Lightpath Algorithm

Proof Min_K_Lightpath

1. First, we let x_j^t be the t-link-disjoint shortest path for wavelength j, shown as following.

	1-shortest	2-shortest	3-shortest	4-shortest	t-shortest
λ_1	x_1^1	x_1^2	x_1^3	x_1^4		x_1^t
λ_2	x_2^1	x_2^2	x_2^3	x_2^4		x_2^t
λ_3	x_3^1	x_3^2	x_3^3	x_3^4		x_3^t
.....
λ_{j-1}	x_{j-1}^1	x_{j-1}^2	x_{j-1}^3	x_{j-1}^4		x_{j-1}^t
λ_j	x_j^1	x_j^2	x_j^3	x_j^4		x_j^t

2. While the traffic demand of od-pair w is one, we choose the smallest x_s^1 as the shortest path, and np_s is set to 1.

While the traffic demand of od-pair w is two, we choose the smallest among

$$x_j^{np_j+1} - x_j^{np_j} \text{ for all the wavelength } j.$$

We can show that it is impossible to choose x_p^2 , while $p \neq s$, because

$$x_p^2 \geq 2x_p^1 \geq x_p^1 + x_s^1.$$

3. Since the traffic demand from 1 to 2, we choose the smallest $x_j^{np_j+1} - x_j^{np_j}$. We

assume the traffic demand from k to $k+1$, we can choose the smallest $x_j^{np_j+1} - x_j^{np_j}$.

If the traffic demand is $k+2$, we can show that it is impossible to choose $x_j^{np_j+M} -$

$x_j^{np_j}$, while $M \geq 2$, and sacrifice some original selected path by Lemma 3.1 which

is given in Table 3-3.

4. Since we already know that from k to $k+1$, it is held. Then we prove that from $k+1$ to $k+2$ traffic demands, it is still held. According to the mathematical induction, for all n to $n+1$ traffic demands, we can always choose the smallest $x_j^{np_j+1} - x_j^{np_j}$ as the $n+1$ smallest cost lightpaths.

Table 3-3 Lemma 3.1

Lemma 3.1

1 While $M=2$, $x_j^{np_j+2} - x_j^{np_j} \geq 2(x_j^{np_j+1} - x_j^{np_j}) \geq (x_j^{np_j+1} - x_j^{np_j}) + (x_i^{np_i} - x_i^{np_i-1})$, where i

is the biggest $x_i^{np_i} + x_i^{np_i-1}$ among all the wavelength.

2 We assume while $M=m$, it is not possible to choose $x_j^{np_j+m} - x_j^{np_j}$, and sacrifice some original selected path.

While $M=m+1$, $x_j^{np_j+m+1} - x_j^{np_j} \geq (x_j^{np_j+m+1} - x_j^{np_j+m}) + (x_j^{np_j+m} - x_j^{np_j})$, where

$(x_j^{np_j+m+1} - x_j^{np_j+m}) \geq (x_i^{np_i} - x_i^{np_i-1})$, where i is the biggest $x_i^{np_i} + x_i^{np_i-1}$ among all the wavelength.

Hence, we find that While $M=m+1$, it is not possible to choose $x_j^{np_j+m+1} - x_j^{np_j}$, and sacrifice some original selected path.

3 According to the mathematical induction, for all $M \geq 2$, traffic demand from $k+1$ to $k+2$, it is impossible to choose any $x_j^{np_j+M} - x_j^{np_j}$, and sacrifice some original selected path.

3.2.2 Subproblem 2

$$Z_{sub3.2}(q, r, s, t, u, v)$$

$$= \text{Min} \left[\sum_{n \in N} (\Psi_n(F_n) + \Omega_n(Z_n) + \Phi_n(U_n)) - \sum_{j \in J} \left(\sum_{l \in L^a} r_{lj} a_l + \sum_{l \in L^b} s_{lj} b_l + \sum_{l \in L^c} t_{lj} c_l + \sum_{l \in L^s_a} u_{lj} d_l + \sum_{l \in L^s_b} v_{lj} e_l \tau_{lj} \right) \right] \quad (\text{SUB 3.2})$$

subject to

$$F_n + Z_n + U_n = 1 \quad \forall n \in N \quad (3.4)$$

$$F_n = 0 \text{ or } 1 \quad \forall n \in N \quad (3.5)$$

$$Z_n = 0 \text{ or } 1 \quad \forall n \in N \quad (3.6)$$

$$U_n = 0 \text{ or } 1 \quad \forall n \in N \quad (3.7)$$

$$a_l \sigma_{lv} = F_n \quad \forall l \in L^a, v \in Y_n^{in} \cup Y_n^{out}, n \in N \quad (3.8)$$

$$b_l \sigma_{lv} = Z_n \quad \forall l \in L^b, v \in Y_n^{in} \cup Y_n^{out}, n \in N \quad (3.9)$$

$$c_l \sigma_{lv} = U_n \quad \forall l \in L^c, v \in Y_n^{in} \cup Y_n^{out}, n \in N \quad (3.10)$$

$$a_l = 0 \text{ or } 1 \quad \forall l \in L^a \quad (3.11)$$

$$b_l = 0 \text{ or } 1 \quad \forall l \in L^b \quad (3.12)$$

$$c_l = 0 \text{ or } 1 \quad \forall l \in L^c \quad (3.13)$$

$$\sum_{l \in L^s_a} d_l \sigma_{lv} = F_n \quad \forall v \in V_n^{in}, n \in N \quad (3.14)$$

$$\sum_{l \in L^s_a} d_l \sigma_{lv} = F_n \quad \forall v \in V_n^{out}, n \in N \quad (3.15)$$

$$\sum_{l \in L^s_b} e_l \theta_{lb} \sigma_{lv} = Z_n \quad \forall b \in B_n, v \in V_n^{in}, n \in N \quad (3.16)$$

$$\sum_{l \in L^s_b} e_l \theta_{lb} \sigma_{lv} = Z_n \quad \forall b \in B_n, v \in V_n^{out}, n \in N \quad (3.17)$$

$$d_l = 0 \text{ or } 1 \quad \forall l \in L^s_a \quad (3.18)$$

$$e_l = 0 \text{ or } 1 \quad \forall l \in L^s_b \quad (3.19)$$

$U_n, F_n, Z_n, a_b, b_b, c_b, d_b,$ and $e_b,$ they can be decomposed into $|\mathcal{N}|$ independent subproblems, each of which can be solved by an exhaustive search on U_n, F_n, Z_n to determine $a_b, b_b, c_b, d_b,$ and $e_b.$ While determining d_b and $e_b,$ we need to implement Bipartite Weighted Matching algorithm [11] to decide the second layer phantom links that match the second layer phantom nodes.

For each node $n,$ we only need to run a bipartite matching algorithm $|J|/|B|+1$ times ($|J|/|B|$ times for waveband switch, 1 time for fiber switch). Hence, the time complexity of subproblem 2 for each node is $O[(|J|/|B|)*(Inc_n)^3],$ where Inc_n is the number of incident fibers to node $n.$



3.3 The Dual Problem and the Subgradient Method

Based on the algorithms for solving the subproblems, we can find the optimal solution of the Lagrangean problem effectively. According to the weak Lagrangean duality theorem, for any given nonnegative Lagrangean multiplier, the optimal solution of the Lagrangean relaxation problem's objective function is the lower bound of the original problem. We use the subgradient method to solve this problem as follows:

$$Z_D = \min Z_{D1}(q, r, s, t, u, v) \quad (D)$$

subject to:

$$q, r, s, t, u, v \geq 0 \quad (3.20)$$



Let S be the subgradient vector of $Z_{D1}(q, r, s, t, u, v)$. During the k^{th} iteration of the subgradient optimal procedure, the multiplier vector $m^k = (q^{1k}, r^{2k}, s^{3k}, t^{4k}, u^{5k}, v^{6k})$ is renewed by the function $m^{k+1} = m^k + \alpha^k S^k$. $S^k(q, r, s, t, u, v) = (\sum_{w \in W} \sum_{p \in P_w} x_{pj} \delta_{pl} - 1,$

$$\sum_{w \in W} \sum_{p \in P_w} x_{pj} \delta_{pl} - a_l, \quad \sum_{w \in W} \sum_{p \in P_w} x_{pj} \delta_{pl} - b_l, \quad \sum_{w \in W} \sum_{p \in P_w} x_{pj} \delta_{pl} - c_l, \quad \sum_{w \in W} \sum_{p \in P_w} x_{pj} \delta_{pl} - d_l,$$

$$\sum_{w \in W} \sum_{p \in P_w} x_{pj} \delta_{pl} - e_l \tau_{ij}). \quad \text{The quantity of } \alpha^k \text{ is decided by the value: } \delta \frac{Z_{IP}^k - Z_{D1}(m^k)}{\|S^k\|^2},$$

where Z_{IP}^k is the lower bound value of the original problem's objective function at the k^{th} iteration, and δ is a constant ($0 \leq \delta \leq 2$).



Chapter 4 Getting Primal Feasible Solutions

4.1 Getting Primal Algorithms

First, we take the recommended switch nodes from the subproblem 2 and the multiplier value as the link weight. For each OD-pair's traffic demand, we run Dijkstra shortest path algorithm on each wavelength layer. We then choose the smallest wavelength layer as the lightpath for this traffic demand and set the link weight all along the path to be infinite. If we cannot find any path for the OD-pair's demand, we calculate the average wasted lambda of every node, pick the node with highest average wasted lambda, and update it (from the fiber switch to the waveband switch or from the waveband switch to the lambda switch). After updating the node, we reroute all the traffic demands from the beginning. When we have satisfied all the traffic demands, that is the primal feasible solution. We then downgrade the updated nodes as the updated sequence, and reroute all the traffic demands again. If there is no feasible solution, we update the node to the original switch and downgrade next node. After trying downgrade every updated node, we will find a better feasible solution. If all switch nodes are lambda switches and we still cannot find a path for a demand, there is no feasible solution. The algorithm is shown in Table 4-1.

Table 4-1 Getting Primal Heuristic Algorithm

Algorithm Primal Heuristic

begin

for each node $n \in N$ **do**

begin

for each link $l \in L, L^{F_a}, L^{F_b}, L^{F_c}, L^{S_a}, L^{S_b}$ **do** $cost_{lj} := \infty$;

for each link $l \in L$ **do** $cost_{lj} := q_{lj}$;

if $F_n := 1$ **for** each link $l \in L^{F_a}$ **do** $cost_{lj} := r_{lj}$; **for** each link $l \in L^{S_a}$ **do** $cost_{lj} := u_{lj}$;

if $Z_n := 1$ **for** each link $l \in L^{F_b}$ **do** $cost_{lj} := s_{lj}$; **for** each link $l \in L^{S_b}$ **do** $cost_{lj} := v_{lj}$;

if $U_n := 1$ **for** each link $l \in L^{F_c}$ **do** $cost_{lj} := t_{lj}$;

end

for each OD pair $sd := 1$ to $|S|$ **do** $num\text{-}path\text{-}setup_{sd} := 0$;

repeat

for each OD pair $sd := 1$ to $|S|$ **do**

begin

if $num\text{-}path\text{-}setup_{sd} < \lambda_w$ **then**

begin

run Dijkstra's-shortest-path on each wavelength layer;

if the shortest path exists **then**

begin

 designate the wavelength associated with the shortest path j^* ;

for all links l on the shortest path **do**

begin $cost_{lj^*} := \infty$;

if $l \in L^{S_a}, L^{S_b}$ **then** set links to other fibers in this node be infinite;

end;

end;

else if all the nodes are lambda switches **then**

return "infeasible";

else for each node n **do** calculate the average wasted lambdas $wasted_n$

 find the largest $wasted_{n^*}$;

if $F_{n^*} := 1$ **then** $F_{n^*} := 0, Z_{n^*} := 1$, update the corresponding link cost;

if $Z_{n^*} := 1$ **then** $Z_{n^*} := 0, U_{n^*} := 1$, update the corresponding link cost;

end;

end;

end;

until all OD pair demand are satisfied;

```

for each node updated
    downgrade the node as the updating sequence;
    if there is no feasible solution, then
        upgrade the node to the original switch
    else find a better feasible solution.
end;
update the upper bound;
end.

```

The average wasted lambda of each node is calculated as follows. At each node, we first calculate the wasted lambdas from each input fiber (waveband) to the corresponding output fiber (waveband). We then calculate the average number of values at every node and pick the largest node to update to the waveband switch (lambda switch).

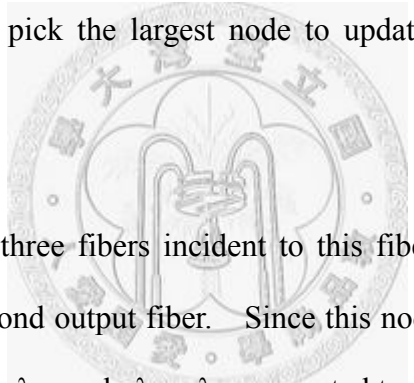

In Fig.4-2, there are three fibers incident to this fiber switch node. The first input fiber is routed to second output fiber. Since this node is the destination of $\lambda_1 \sim \lambda_{16}$ and is the source of $\lambda_{21} \sim \lambda_{32}$, only $\lambda_{17} \sim \lambda_{20}$ are routed to the second output fiber. If we update this node to a waveband switch, $\lambda_{21} \sim \lambda_{32}$ can be routed to other output fibers, because these wavelengths are on other wavebands. Hence, the number of wasted lambdas of the first fiber at this node is 12.

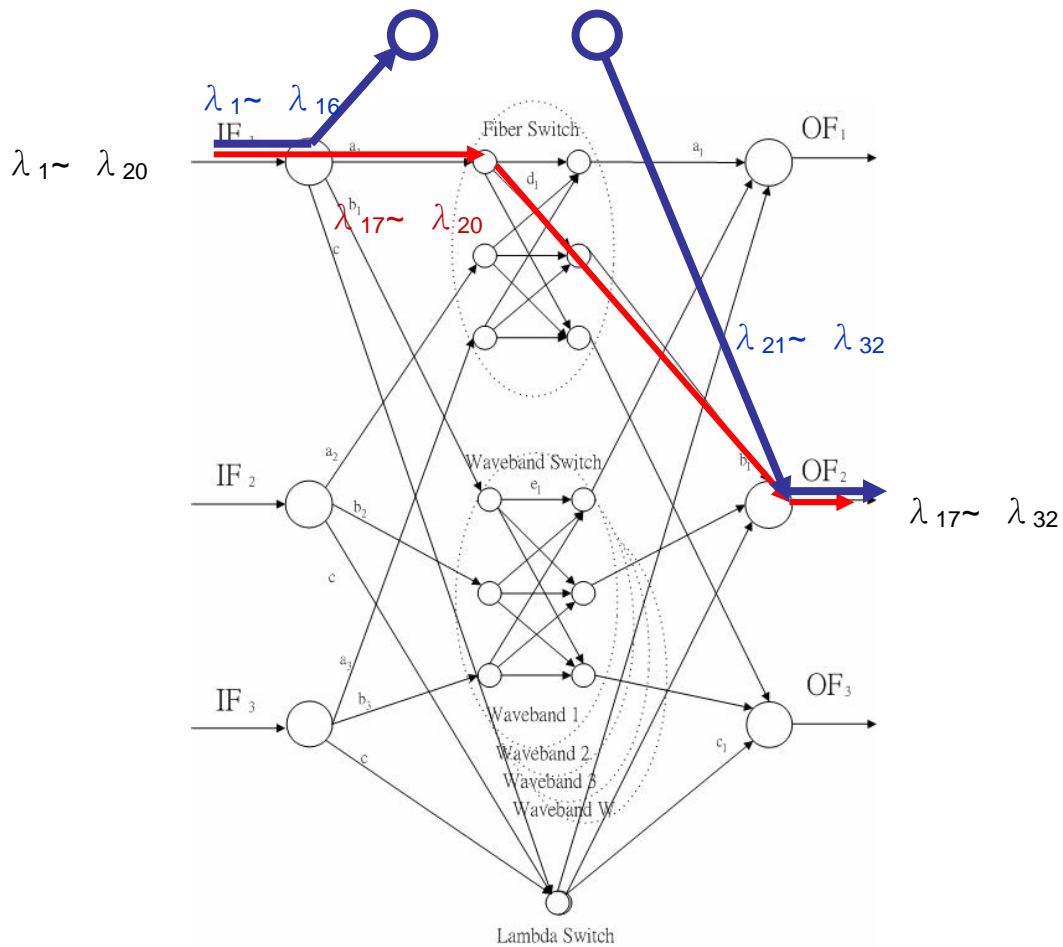

Figure 4-1 Wasted Lambda Calculation

4.2 Simple Heuristic Algorithms

In addition to using Lagrangean relaxation, we have also developed a simple heuristic algorithm, which is a modified version of the heuristic algorithm in [8]. If we cannot find a path for a traffic demand, we take the routing and wavelength assignment idea from [8], without seeing the multiplier information and the solutions of subproblems, as the RWA method in this heuristic and the switch update criteria from the getting primal heuristic algorithm in Section 4.1. The simple heuristic algorithm is shown in Table 4-2.

Table 4-2 Simple Heuristic Algorithm

Algorithm Simple Heuristic Algorithm

begin

for each node $n \in N$ **do**

begin

$F_n := 1$;

for each link $l \in L, L^{F_a}, L^{F_b}, L^{F_c}, L^{S_a}, L^{S_b}$ **do** $cost_{lj} := \infty$;

for each link $l \in L$ **do** $cost_{lj} := 1$;

for each link $l \in L^{F_a}$ **do** $cost_{lj} := 1$; **for** each link $l \in L^{S_a}$ **do** $cost_{lj} := 1$;

end

for each OD pair $sd := 1$ to $|S|$ **do** num-path-setup $_{sd} := 0$;

repeat

for each OD pair $sd := 1$ to $|S|$ **do**

begin

if num-path-setup $_{sd} < \lambda_w$ **then**

begin

run Dijkstra's-shortest-path on each wavelength layer;

if the shortest path exists **then**

begin

 designate the wavelength associated with the shortest path j^* ;

for all links l on the shortest path **do**

begin $cost_{lj^*} := \infty$;

if $l \in L^{S_a}, L^{S_b}$ **then** set links to other fibers in this node be infinite;

end;

end;

else if all the nodes are lambda switches **then**

return "infeasible";

else for each node n **do** calculate the average wasted lambdas $wasted_n$

 find out the biggest $wasted_{n^*}$;

if $F_{n^*} := 1$ **then** $F_{n^*} := 0, Z_{n^*} := 1$, update the corresponding link cost;

if $Z_{n^*} := 1$ **then** $Z_{n^*} := 0, U_{n^*} := 1$, update the corresponding link cost;

end;

end;

end;

until all OD pair demand satisfied;

```

for each node updated
    downgrade the node as the updating sequence;
    if there is no feasible solution, then
        upgrade the node to the original switch
    else find a better feasible solution.
end;
update the upper bound;
end.

```

We will compare the solution quality of LR and this simple heuristic algorithm (SA) in Chapter 5. Getting primal heuristic algorithm of LR1 and simple algorithm (SA1) do not consider the node downgrading process after finding a feasible solution. Getting primal heuristic algorithm of LR2 and simple algorithm (SA2) take node downgrading into consideration.

The complexity of getting primal heuristic algorithm of LR1 for each iteration is $O(|J|nk(phn)^2)$ where k is the number of lighpaths, n is the number of nodes, and phn is the number of phantom nodes. The complexity of getting primal heuristic algorithm of LR1 for each iteration is also $O(|J|nk(phn)^2)$.

Chapter 5 Computational Experiments

5.1 Experiment Environment

In this chapter, we conduct several computational experiments to test the solution quality and effectiveness of our solution approach. In the following, we conduct the following experiments: from a small network topology to a large network topology, and from a high connectivity network to a low connectivity network; Table 5-1 shows the general parameter settings for the computational experiments.

Table 5-1 Parameters of the computational experiments

Number of Nodes	7 ~ 28
Number of Links	28 ~ 90
Number of wavelengths	16 ~ 32
Number of wavebands	4
Number of lighpaths	120 ~ 280
Number of Iteration	1000
Improvement Counter	20
Initial Upper Bound	Cost of lambda switches at every node

Initial Scalar of Step Size	2
Test Platform	CPU : Intel Pentium-4 2.4 GHz, AMD K8 2.4GHz OS : MS Windows 2000 MS Windows XP

5.2 Seven-node Small Network

5.2.1 Network Topology

The seven-node small network topology is shown in Fig. 5-2, and general information about the network is given in Table 5-2.

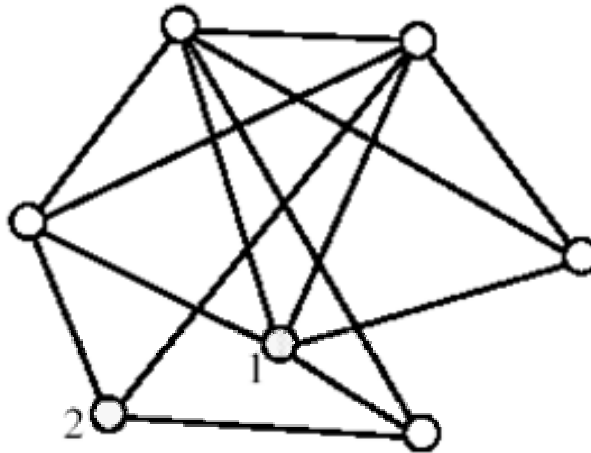

Figure 5-1 Seven-node Small Network Topology

Table 5-2 Seven-node Small Network

Number of Nodes	7
Number of Links	28
Number of wavelengths	16
Number of wavebands	4
Connectivity	0.667
Average node degree	4
OD-pairs number	28
Lightpath Demand of each OD-pair	4.6~6.0
Total number of lightpaths	130~168

5.2.2 Solution Quality

In Fig. 5-2, we observe that the upper and lower bounds converge quite well when the average lightpath demand per OD-pair is 5.1. We can find that the gap between the bounds is between 3% and 45%, as shown in Fig. 5-3. As the lightpath demand increases, the gap between the upper bound lower bound also dramatically increases. The reason is that the cost structure of switches is proportional to the number of ports used. In this case, the waveband switch is four times more expensive than the fiber switch, while the lambda switch is sixteen times more expensive than the fiber switch. Therefore, as traffic demand increases, more waveband and lambda switches are needed, the cost may increase substantially. This is the reason that the upper bound increases dramatically,, while the lower bound increases relatively slowly. Hence, the gap becomes larger.

In Fig. 5-4, as the traffic demand is low, it is easier to route the traffic, so the solutions of SA and LR are very close. However, as the lightpath demand increases, LRs are vastly superior to SAs. In addition, when traffic demand is very heavy, SA can not even find a feasible solution, whereas LR can still find a fairly good solution.

In Table 5-3 we observe that, on average, LRs at at least 100 percent more cost efficient than SAs when the the traffic demand is heavier. However, LR2 is not significantly better than LR1 because the connectivity of the network is too high, and it is hard to downgrade any node.

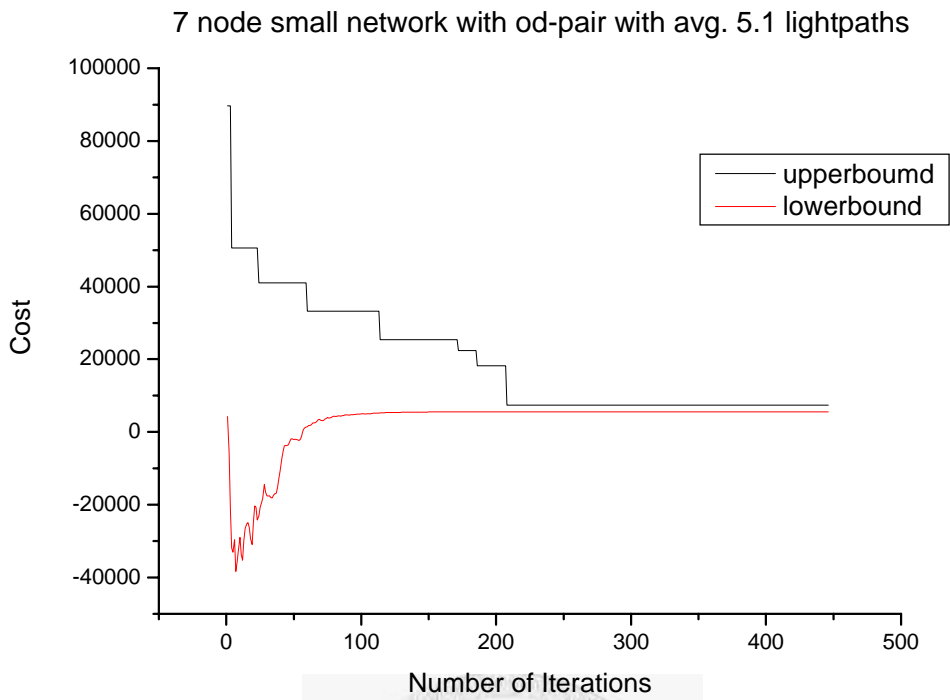

Figure 5-2 The upper and lower bounds of the seven-node network

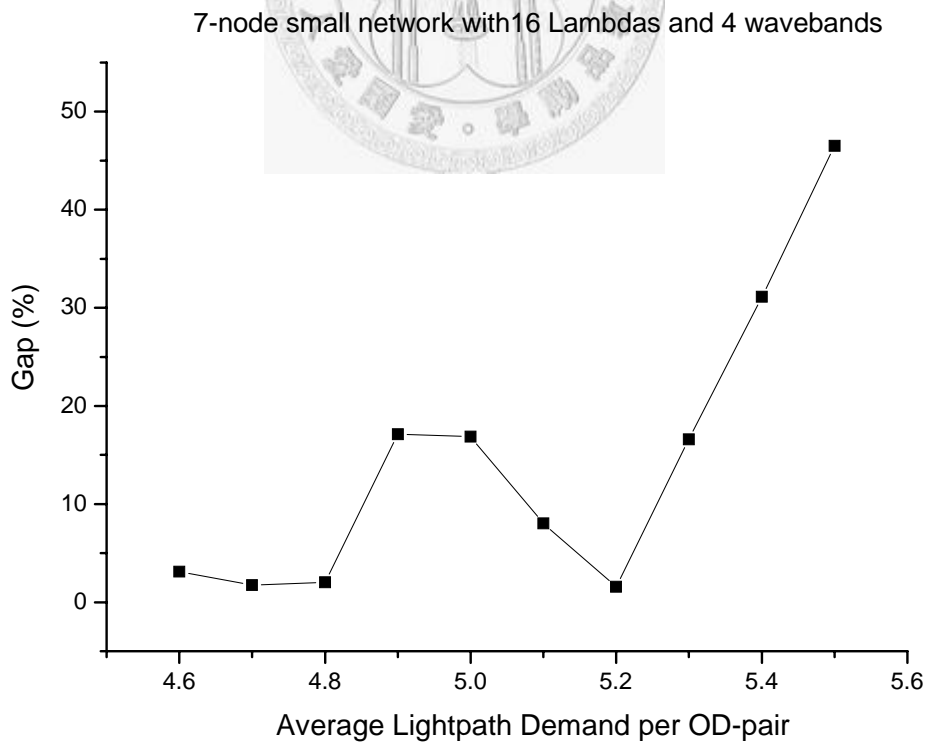

Figure 5-3 Gap of different traffic demand

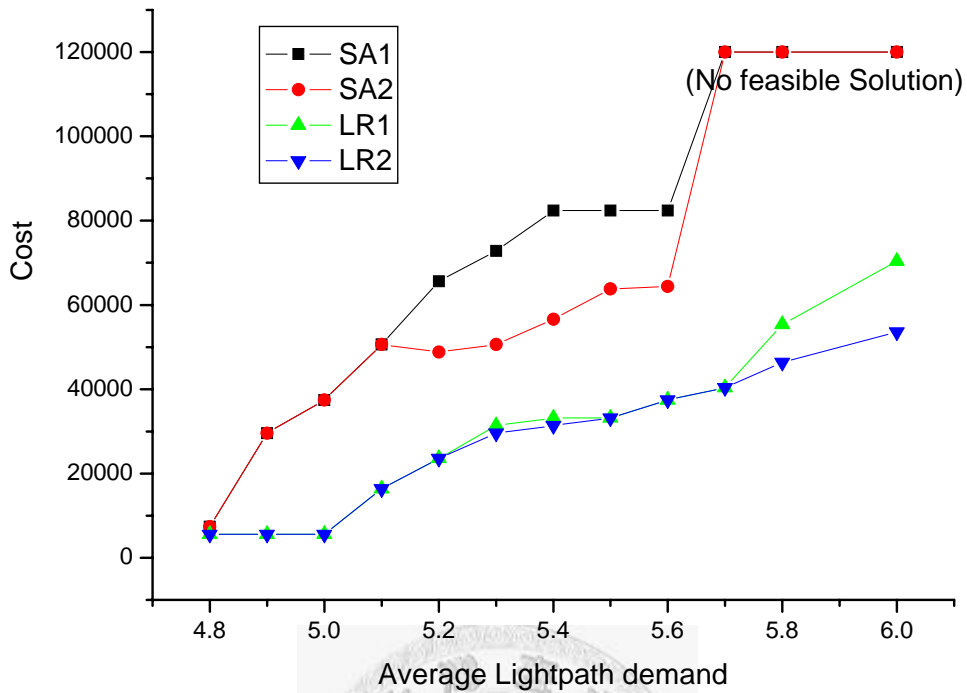

Figure 5-4 The SA and LR solution quality in the 7-node small network

Table 5-3 The improvement ratio in 7-node network

Avg. Lightpath Demand of each OD-pair	SA1	LR1	Improvement ratio(%)	SA2	LR2	Gap(%)	Improvement ratio(%)
4.8	7400	5600	32.14	7400	5600	3.12	32.14
4.9	29600	5600	428.57	29600	5600	1.73	428.57
5	37400	5600	567.86	37400	5600	2.01	567.86
5.1	50600	16400	208.54	50600	16400	17.10	208.54
5.2	65600	23600	177.97	48800	23600	16.87	106.78
5.3	72800	31400	131.85	50600	29600	8.03	70.95
5.4	82400	33200	148.19	56600	31400	1.56	80.25
5.5	82400	33200	148.19	63800	33200	16.57	92.17
5.6	82400	37400	120.32	64400	37400	31.14	72.19
5.7	No feasible	40400	∞	No feasible	40400	46.51	∞
5.8	No feasible	55400	∞	No feasible	46400	74.11	∞
6	No feasible	70400	∞	No feasible	53600	117.63	∞

5.2.3 Computation Time

In Fig.5-5, we can see that as the traffic demand increases, the number of iterations also increases. In Fig. 5-6, the computation time also increases as the traffic demand increases, because more switch nodes are updated, and once a node is updated, all the traffic demand must be rerouted from the beginning.

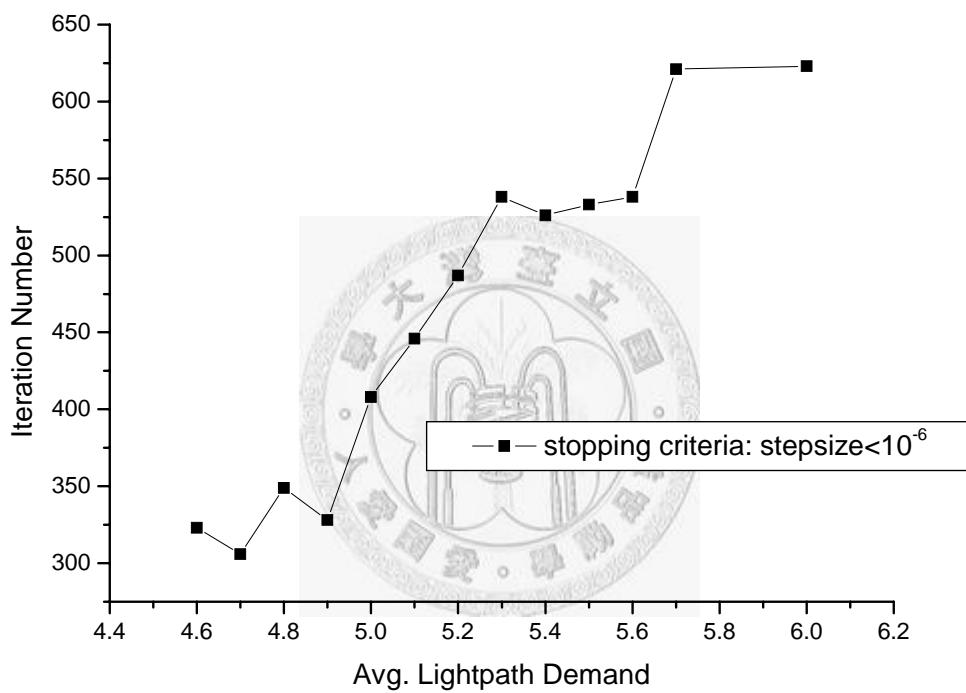

Figure 5-5 The number of iterations in the 7-node network

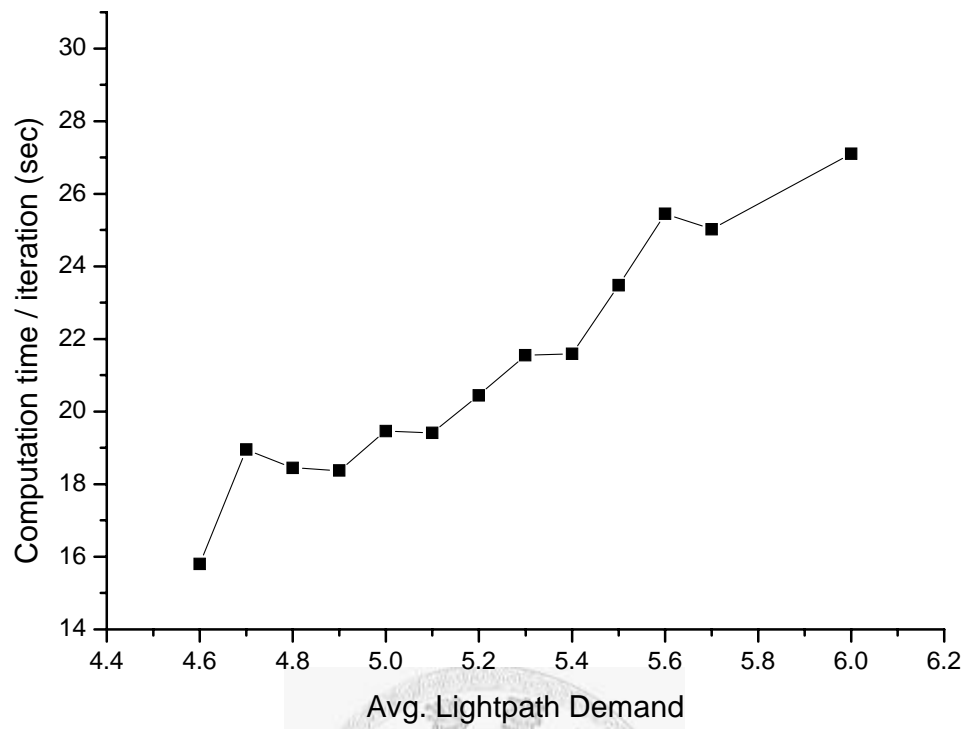
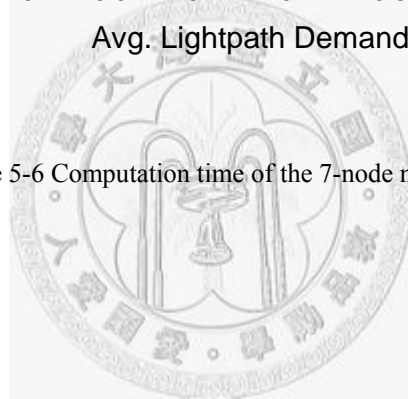

Figure 5-6 Computation time of the 7-node network



5.3 GTE Network

5.3.1 Network Topology

The GTE network is a well known medium-sized network often used for computational experiments. The network's topology is shown in Fig. 5-7, and general information about the network is given in Table 5-4.

Table 5-4 GTE Network

Number of Nodes	12
Number of Links	50
Number of wavelengths	16
Number of wavebands	4
Connectivity	0.379
Average node degree	4.167
Number of OD-pairs	40-70
Lightpath Demand of each OD-pair	4
Total number of lightpaths	160~280

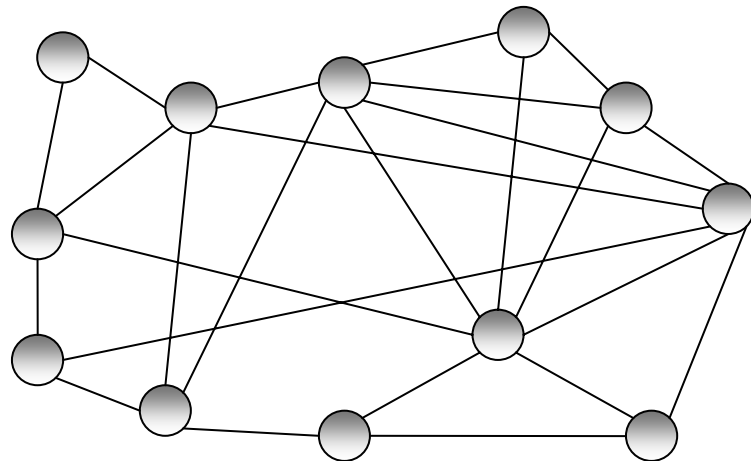

Figure 5-7 The GTE Network Topology

5.3.2 Solution Quality

The convergence between the upper and lower bounds of 35 OD-pairs with a traffic demand of four wavelengths is shown in Fig. 5-8. In Fig. 5-9, we find that as the number of OD-pairs increases, LR performs better than SA. Furthermore, the improvement ratios shown in Table 5-5 confirm that LRs are much more cost effective than SAs. LR2 is better than LR1 in about 10-20 % because as the network size increases, there are potentially more nodes which were updated before can be downgraded after some other nodes updated later.

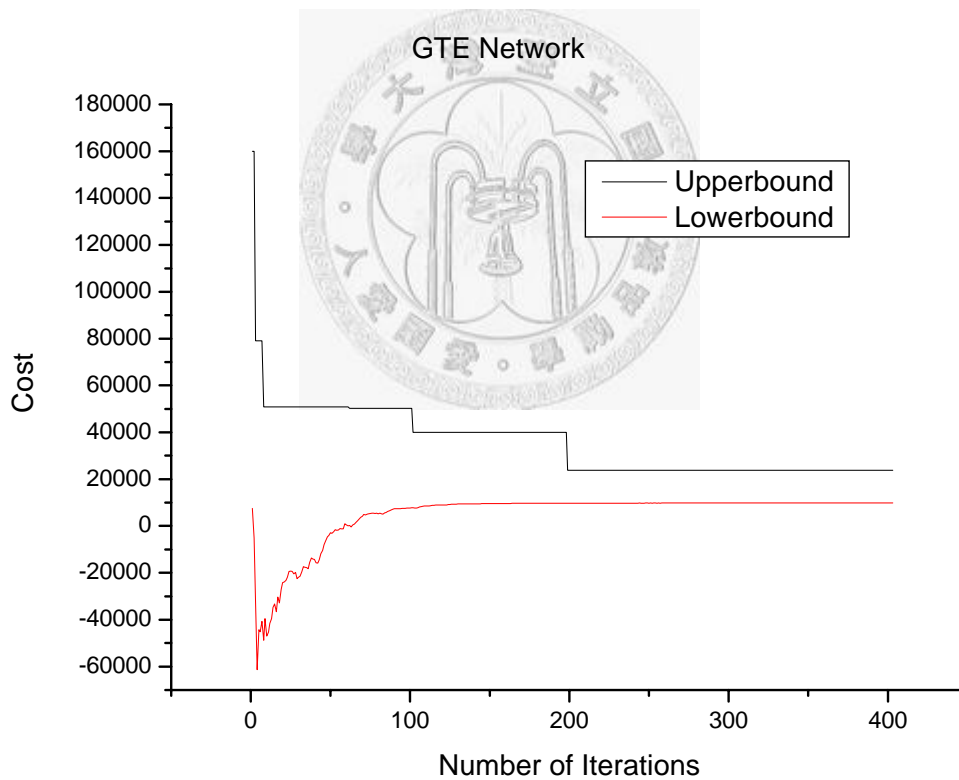

Figure 5-8 The upper and lower bounds in the GTE Network

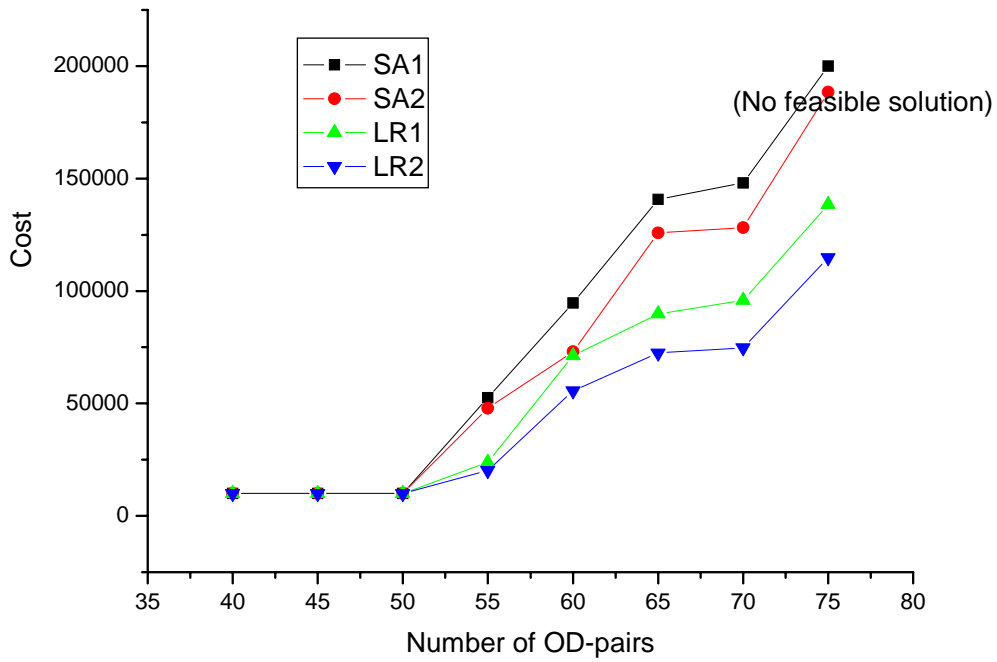

Figure 5-9 The solution quality of SA and LR in the GTE network

Table 5-5 The improvement ratios of the GTE network

OD pair	SA1	LR 1	improvement ratio(%)	SA2	LR2	improvement ratio(%)
40	10000	10000	0	10000	10000	0
45	10000	10000	0	10000	10000	0
50	10000	10000	0	10000	10000	0
55	52600	23800	121.00	47800	20200	136.63
60	94600	71200	32.87	73000	55600	31.295
65	140800	89800	56.79	125800	72400	73.76
70	148000	95800	54.49	128200	74800	71.39
75	No feasible	138400	∞	No feasible	114800	∞

5.4 USA Network

5.4.1 Network Topology

The USA network topology is shown in Fig. 5-10, and general information about it is given in Table 5-6. Compared to the GTE network, the USA network is a much larger topology.

Table 5-6 The USA Network

Number of Nodes	28
Number of Links	90
Number of wavelengths	16
Number of wavebands	4
Connectivity	0.12
Average node degree	3.214
Number of OD-pairs	30-50
Lightpath Demand of each OD-pair	4
Total number of lightpaths	120~200

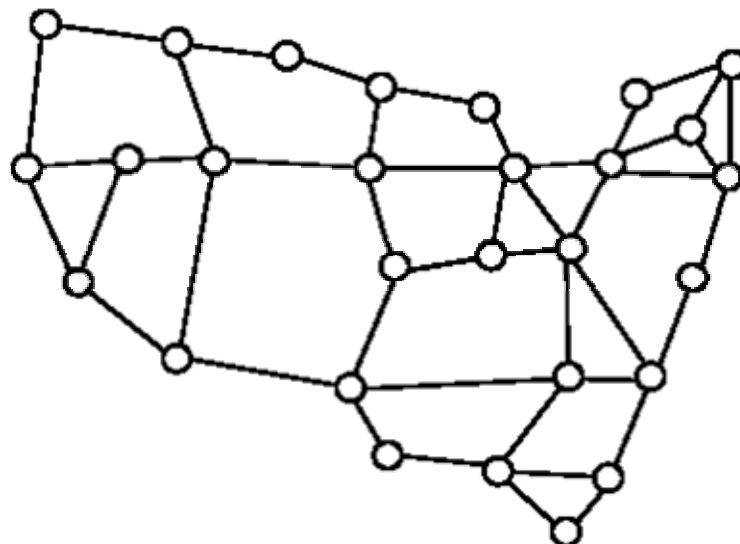

Figure 5-10 The USA Network topology

5.4.2 Solution Quality

Fig. 5-11 shows the convergence of the upper and lower bounds in the USA network with 32 OD-pairs. In Fig. 5-12 and Table 5-7, the LRs performance are between 50 percent to 100 percent better than that of SAs. LR2 is better than LR1 in about 5-10 % because as the network size increases, there are potentially more nodes which were updated before can be downgraded after some other nodes updated later.

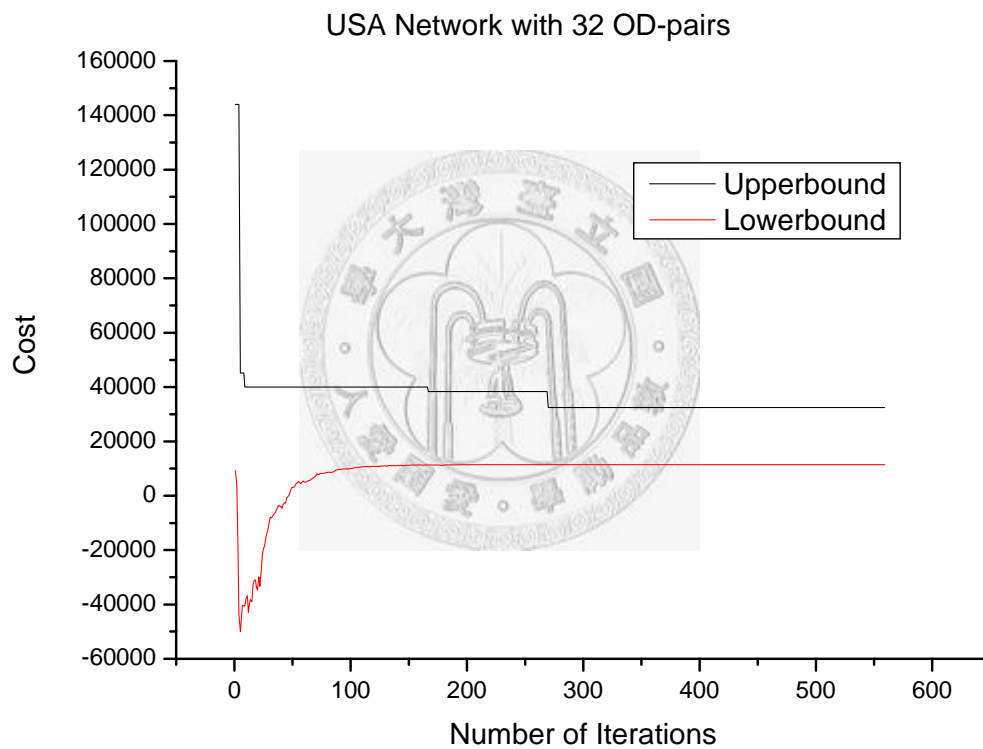

Figure 5-11 The upper bound and lower bounds of the USA network

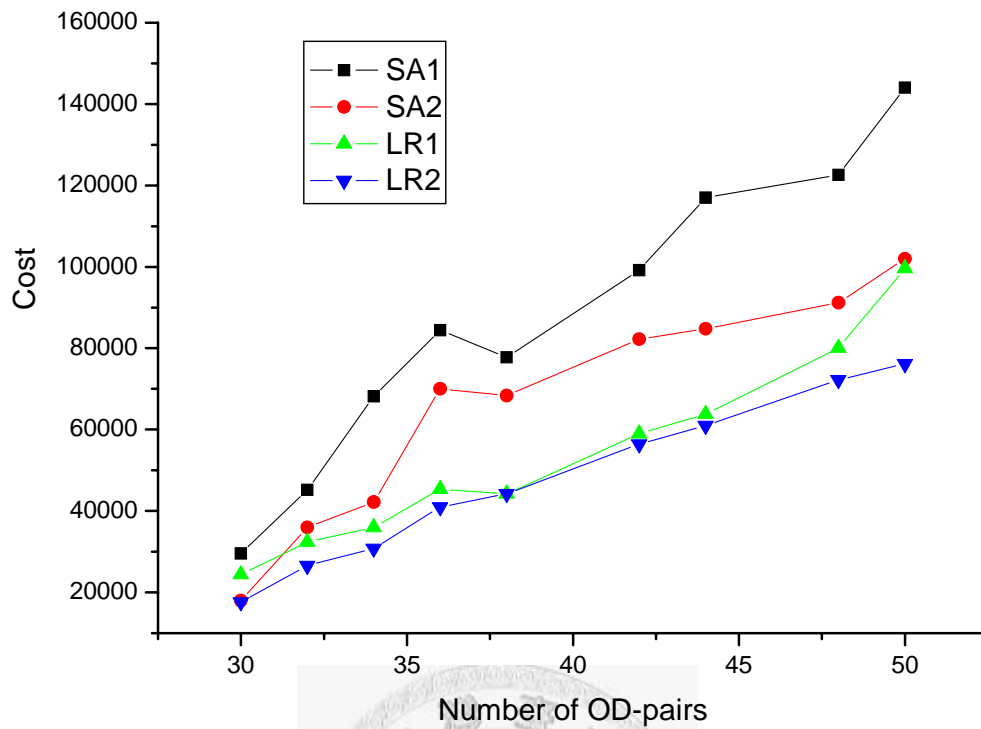

Figure 5-12 SA and LR solution quality in the USA network

Table 5-7 The improvement ratios of the USA network

OD-pair	SA1	LR1	improvement ratio(%)	SA2	LR2	improvement ratio(%)
30	29600	24400	21.31	18000	17600	2.27
32	45200	32400	39.51	36000	26600	35.34
34	68200	36000	89.44	42200	30800	37.01
36	84400	45400	85.90	70000	41000	70.73
38	77800	44200	76.02	68400	44200	54.75
42	99200	59000	68.14	82200	56400	45.74
44	117000	63800	83.39	84800	61000	39.02
48	122600	80000	53.25	91200	72200	26.32
50	144000	99600	44.58	102000	76200	33.86

5.4.3 Computation Time

As we can see in Figures 5-13 and 5-14, the number of iterations and the computation time both increase as the OD-pair traffic demand increases. The reason is that there are more updated nodes when the lightpath demand is heavy.

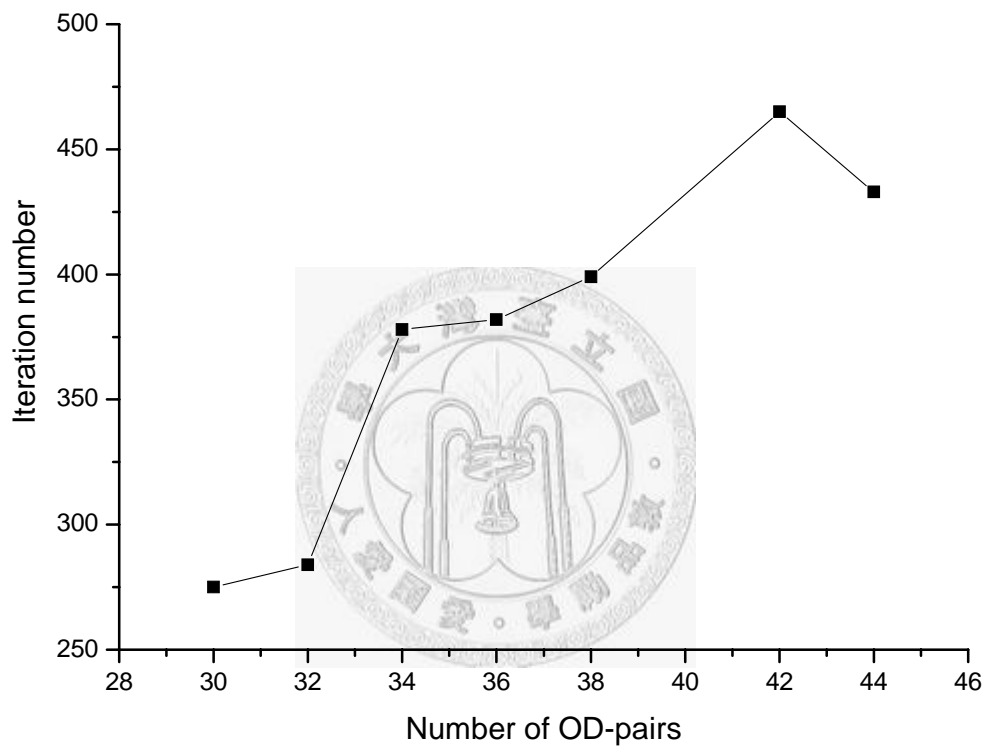

Figure 5-13 The number of iterations in the USA Network

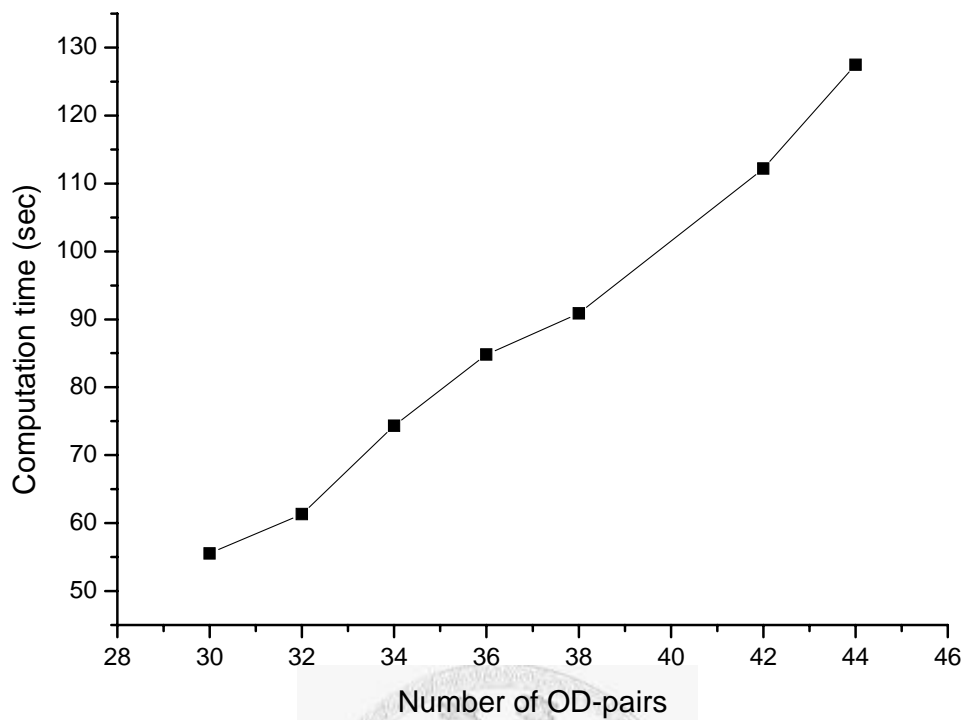

Figure 5-14 The computation time of the USA network

5.5 Discussion

5.5.1 Number of Wavelengths

From a small 7-node network to a large USA network, we find that our LR approach always outperforms the SA approach.

With a fixed traffic demand, as the wavelengths in a fiber increase, the cost decreases. In Fig. 5-15, there are 55 OD-pairs, each of which has four lightpaths. We believe that as DWDM technology improves, which means that the number of wavelengths carried in a fiber will increase, the overall cost of planning will decrease. This observation is shown in Fig. 5-15 with 8 wavelengths, 12 wavelengths, 16

wavelengths, and 20 wavelengths.

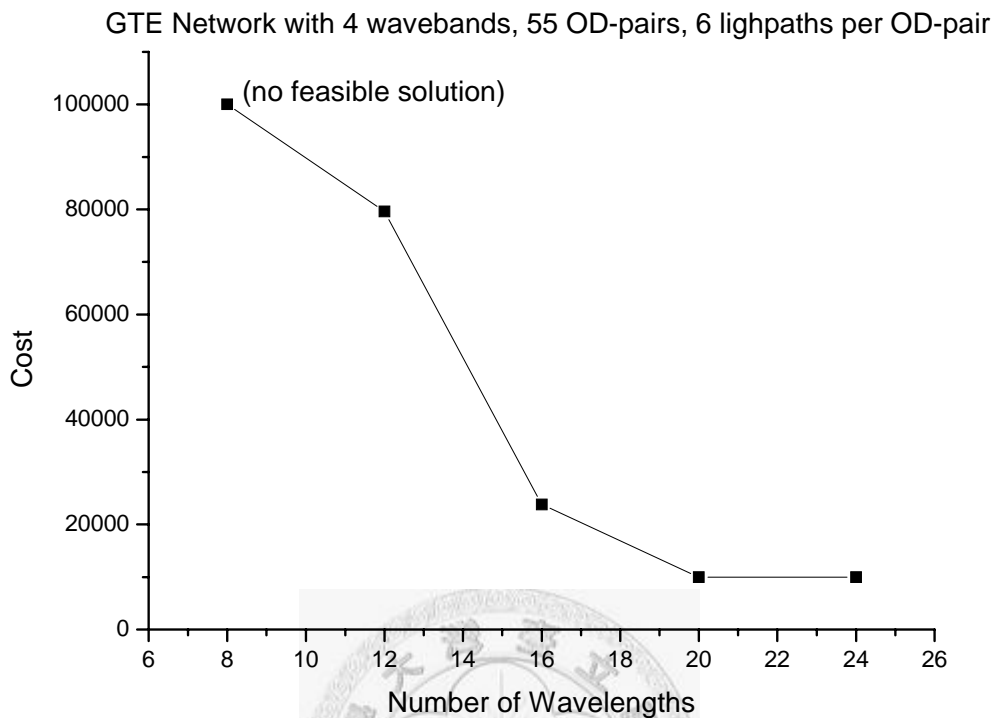

Figure 5-15 The cost structure of different numbers of wavelengths in a fiber

5.5.2 Number of Wavebands

With a fixed traffic demand, if the number of wavebands in a fiber is too many or too few, the cost increases. Since the number of wavebands that a fiber can be divided into is also an input parameter, we must decide the number of wavebands before switch allocation and RWA.

In Fig. 5-16, we can see that the cost is lowest when the number of wavebands is moderate in the GTE network with 24 lambdas. There are 55 OD-pairs, each of which has six lightpaths. . If there are too many wavebands, a waveband switch will be closer to a lambda switch, and the cost will be higher because there will be too many

ports in the waveband switch. On the other hand, if there are too few wavebands, a waveband switch will be closer to a fiber switch, and the cost is higher because too many waveband switches will be updated to lambda switches. This observation provides a good guideline for deciding the number of wavebands.

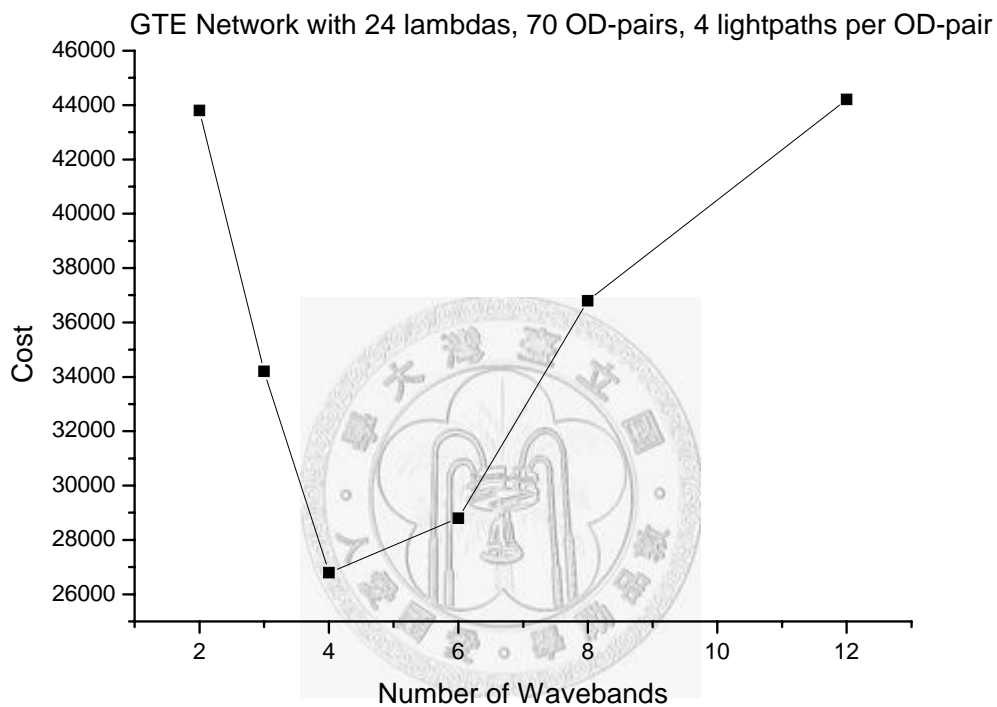

Figure 5-16 Cost structure of different number of waveband in a fiber

5.5.3 Scalability

As we can see in the time complexity analysis, we find that Subproblem 1 (each OD-pair: $O(|J|n^2+k^2(phn)^2\log(phn))$) or getting primal heuristic ($O(|J|nk(phn)^2)$) dominates the complexity. We find that when the number of wavelengths increases, the computation time will increase linearly; when the number of phantom nodes increases, the computation time will at most increase proportionally to $(phn)^2\log(phn)$.

Note that the number of phantom nodes is proportional to the number of physical links. Therefore, even as DWDM technology improves or the network topology becomes larger, the computation time can still be handled in the acceptable range. If we have powerful computers, the scalability will be much better.



Chapter 6 Conclusion and Future Work

6.1 Conclusion

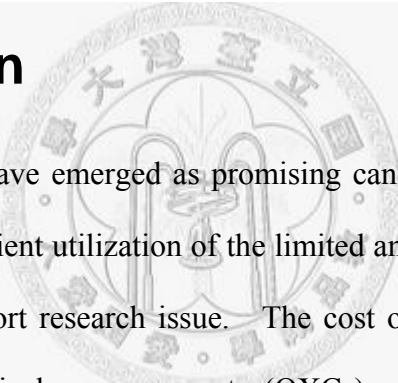

As WDM networks have emerged as promising candidates for future networks with large bandwidth, efficient utilization of the limited and expensive components in networks becomes an important research issue. The cost of optical network planning results primarily from optical cross-connects (OXC)s, while the cost of which is proportioned to the number of ports used. WDM technology has improved so rapidly that a fiber can carry more than 200 wavelengths, however, the cost associated with the lambda switch is extremely high when there are so many ports. Furthermore there are limitations to the switch design with so many ports.

In the past, most research has focused on the routing and wavelength assignment (RWA) problem with lambda switch nodes, but this is not applicable anymore. [8] first proposed a mathematical formulation to solve the RWA problem with different switches (i.e., a fiber capable switch or a lambda capable switch), but the switch nodes must be determined first. However, the authors do not propose a good way to

allocate the switch nodes.

In GMPLS, it is proposed that FSC (fiber switch capable), WBSC (waveband switch capable), and LSC (lambda switch capable) interfaces be used to generate a general control plane.

With these three kinds of switch, we can allocate switch nodes properly based on the lowest cost, and satisfy all the static traffic demand in a heterogeneous network. In order to solve the problem, we represent it as a mathematical formulation. To the best of our knowledge, this has not been done before. The waveband switch capability is also modeled as a mathematical formulation for the first time. As the integer programming problem itself is highly complicated, we adopt Lagrangean relaxation as the solution approach.

We also propose a simple heuristic algorithm modified from the RWA problem in [8], and conduct several experiments on different network topologies from small-scale to large-scale networks. We find that the experiment results of Lagrangean Relaxation are much better than those of the simple heuristic algorithm. In addition, since it is a planning problem, the computation time is also within a tolerable range. Therefore, it is an excellent approach for dealing with the optical network planning problem in heterogeneous networks.

Finally, we develop some simple principles so that network planners can effectively determine the number of wavelengths a fiber should carry and number of wavebands a fiber should be divided into in an optical planning situation.

6.2 Future Work

Currently, very little researches focuses on network planning in a heterogeneous network. We first model this problem as a mathematical formulation, and provide [8] a good switch allocation guideline for further RWA determination. Our work and [8] both focus on static traffic demand in a heterogeneous network. As for dynamic traffic demand, there is still a great need to conduct more research into network planning and RWA issues.

Some literature discusses optical cross-connects design issues in homogeneous networks [3], [4], [5], [6], [16]. Although a few develop a mathematical formulation, they do not try to solve it by optimization-based methods. Instead, they develop many heuristics to deal with both static and dynamic traffic OXC design issues. It would be worth reformulating this design problem as a solvable mathematical formulation, and solve it by an optimization-based approach. The solution quality would definitely be better than a heuristic-based approach. Therefore, we can use resources more effectively and efficiently.



Reference

- [1] L. Berger, "Generalized Multi-Protocol Label Switching (GMPLS) Signaling Functional Description", IETF RFC 3471, January 2003.
- [2] R. Douville, D. Papadimitriou, and E. Dotaro, "Extensions to Generalized Multi-Protocol Label Switching in support of Waveband Switching", IETF Internet Draft, July 2004.
- [3] Y. Suemura, et al, "Hierarchical Routing in Layered Ring and Mesh Optical Networks", IEEE ICC 2002, May 2002.
- [4] X. Cao, V. Anand, Y. Xiong, and C. Qiao, "A Study of Waveband Switching With Multilayer Multigranular Optical Cross-Connects, IEEE Journal on Selected Areas in Communications, Vol.21, No.7, September 2003.
- [5] X. Cao, V. Anand, and C. Qiao, "A Waveband Switching Architecture and Algorithm for Dynamic Traffic", IEEE Communications Letters, Vol.7 No.8, August 2003.
- [6] P. H. Ho, and H. T. Mouftah, "Routing and Wavelength Assignment With Multigranularity Traffic in Optical Networks", Journal of Lightwave Technology, Vol.20, No.8, August 2002.
- [7] K. Zhu, H. Zhu, and B. Mukherjee, "Traffic Engineering in Multigranularity Heterogeneous Optical WDM Mesh Networks through Dynamic Traffic Grooming", IEEE Network, vol. 17, no. 2, March 2003.
- [8] S. S.W. Lee, M. C. Yuang, P. Tien, and S. Lin, "A Lagrangean Relaxation-Based Approach for Routing and Wavelength Assignment in Multigranularity Optical WDM Networks", IEEE Journal on Selected Areas in Communications, Vol.22, No.9, November 2004.
- [9] J. W. Suurballe, R.E. Tarjan, "A Quick Method for Finding Shortest Pairs of

- Disjoint Paths”, Networks, Vol.14, 1984.
- [10]J. W. Suurballe, “Disjoint Paths in a Network”, Networks, Vol.4, 1974.
- [11]C. H. Papadimitriou, K. Steiglitz, “Combinatorial optimization : algorithms and complexity”, Prentice Hall, 1982.
- [12]R. K. Ahuja, T. L. Magnanti, J. B. Orlin, ”Network flows : theory, algorithms, and applications”, Prentice-Hall International, 1993.
- [13]S. S.W. Lee, “Introduction to IP over Wavelength Division Multiplexing (WDM) Network Technology” Presentation, March 2004.
- [14]J. Bowers, “Fiber Optics” lecture notes in UCSB, 2004.
- [15]R. Helkey, et al, ”Design of Large, MEMS-Based Photonic Switches”, Optics & Photonics News, May 2002
- [16]P. H. Ho, H. T. Mouftah, and J. Wu, ”A Scalable Design of Multigranularity Optical Cross-Connects for the Next-Generation Optical Internet”, IEEE Journal on Selected Areas in Communications, Vol.21, No.7, Sep. 2003.
- [17]M. L. Fisher, “The Larganian Relaxation Method For Solving Integer Programming Problems”, Management Science, Vol.27, No.1, January 1981.
- [18]R. Parthiban, R. S. Tucker, “Waveband Grooming and IP Aggregation in Optical Networks”, IEEE Journal of Lightwave Technology, Vol.21, No.11, November 2003.
- [19]郭至鈞, 以波長 由為基礎之多波長分工網 上群播樹合併演算法 , 國
台灣大學資訊管 學研究所碩士學位 文, 民國九十二 七月。
- [20]顏宏旭著, 電腦網 與後勤網 之規劃與容 管 , 國 台灣大學資訊管
學研究所博士學位 文, 民國九十 月。

簡

姓 名：張孝澤

出生地：台 市

出生日：中華民國七十 三月二日

學 ：

八十八 九月至九十二 月

國 臺灣大學資訊管 學系學士

九十二 九月至九十四 月

國 台灣大學資訊管 學研究所碩士

